

N-Channel Enhancement Mode MOSFET

1. Product Information

1.1 Features

- Surface-mounted package
- Advanced trench cell design
- Super Trench

1.2 Applications

- BMS appliances
- High power inverter system
- Power Tool appliances

1.3 Quick reference

- $BV \cong 150\text{ V}$
- $R_{DS(ON)} \leq 10\text{ m}\Omega @ V_{GS} = 10\text{ V}$
- $P_{tot} \leq 156\text{ W}$
- $R_{DS(ON)} \leq 13\text{ m}\Omega @ V_{GS} = 6\text{ V}$
- $I_D \leq 82\text{ A}$

2. Pin Description

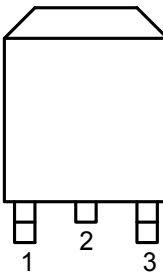
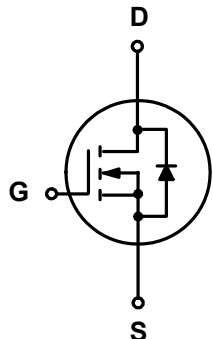
| Pin | Description | Simplified Outline | Symbol |
|-----|-------------|---|---|
| 1 | Gate(G) |  Top View TO263-2L |  |
| 2 | Drain(D) | | |
| 3 | Source(S) | | |

3. Limiting Values

| Symbol | Parameter | Conditions | Min | Max | Unit |
|---------------------|---|--|-----|----------|--------------------|
| V_{DS} | Drain-Source Voltage | $T_C = 25\text{ }^\circ\text{C}$ | 150 | - | V |
| V_{GS} | Gate-Source Voltage | $T_C = 25\text{ }^\circ\text{C}$ | - | ± 25 | V |
| I_D^* | Drain Current (DC) | $T_C = 25\text{ }^\circ\text{C}, V_{GS} = 10\text{ V}$ | - | 82 | A |
| $I_{DM}^{*,**,***}$ | Drain Current (Pulsed) | $T_C = 25\text{ }^\circ\text{C}, V_{GS} = 10\text{ V}$ | - | 180 | A |
| P_{tot}^* | Drain power dissipation | $T_C = 25\text{ }^\circ\text{C}$ | - | 156 | W |
| T_{stg} | Storage Temperature | | -55 | 150 | $^\circ\text{C}$ |
| T_J | Junction Temperature | | - | 150 | $^\circ\text{C}$ |
| I_S | Continuous-Source Current | $T_C = 25\text{ }^\circ\text{C}$ | - | 82 | A |
| $R_{\theta JA}^*$ | Thermal Resistance- Junction to Ambient | | - | 62.5 | $^\circ\text{C/W}$ |
| $R_{\theta JC}^*$ | Thermal Resistance- Junction to Case | | - | 0.8 | |

Notes :

- * Surface Mounted on 1 in² pad area, $t \leq 10\text{ sec}$
- ** Pulse width $\leq 300\text{ }\mu\text{s}$, duty cycle $\leq 2\%$
- *** Limited by bonding wire

4. Marking Information

| Product Name | Marking |
|--------------|---|
| KJ0915D | <div style="display: flex; align-items: center;"> <div style="background-color: black; color: white; padding: 2px 5px; margin-right: 5px;">0915</div> YWW <div style="background-color: black; color: white; padding: 2px 5px; margin-right: 5px;">YWWXXX</div> : Date Code </div> |

5. Ordering Code

| Product Name | Package | Reel Size | Tape width | Quantity | Note |
|--------------|---------|-----------|------------|----------|------|
| KJ0915D | TO263 | | | 800 | |

Note: KUAIJIEXIN defines " Green " as lead-free (RoHS compliant) and halogen free (Br or Cl does not exceed 900 ppm by weight in homogeneous material and total of Br and Cl does not exceed 1500 ppm by weight; Follow IEC 61249-2-21 and IPC / JEDEC J-STD-020C)

6. Electrical Characteristics ($T_A=25^\circ$ Unless Otherwise Noted)

| Symbol | Parameter | Conditions | Min | Typ | Max | Unit |
|--|--------------------------------|---|-----|------|-----------|---------------|
| Static Characteristics | | | | | | |
| BV_{DSS} | Drain-Source Breakdown Voltage | $V_{GS} = 0\text{ V}, I_{DS} = 250\ \mu\text{A}$ | 150 | - | - | V |
| $V_{GS(th)}$ | Gate Threshold Voltage | $V_{DS} = V_{GS}, I_{DS} = 250\ \mu\text{A}$ | 2 | - | 4 | V |
| I_{DSS} | Drain Leakage Current | $V_{DS} = 120\text{ V}, V_{GS} = 0\text{ V}$ | - | - | 1 | μA |
| | | $T_J = 85^\circ\text{C}$ | - | - | 30 | μA |
| I_{GSS} | Gate Leakage Current | $V_{GS} = 0\text{ V}, V_{GS} = \pm 25\text{ V}$ | - | - | ± 100 | nA |
| $R_{DS(ON)}^a$ | On-State Resistance | $V_{GS} = 10\text{ V}, I_{DS} = 30\text{ A}$ | - | 8.8 | 10 | m Ω |
| | | $V_{GS} = 6\text{ V}, I_{DS} = 20\text{ A}$ | - | 10.5 | 13 | |
| Diode Characteristics | | | | | | |
| V_{SD}^a | Diode Forward Voltage | $I_{SD} = 30\text{ A}, V_{GS} = 0\text{ V}$ | - | - | 1.3 | V |
| t_{rr} | Reverse Recovery Time | $I_{DS} = 2\text{ A}, V_{GS} = 0\text{ V}$ $di_{SD}/dt = 100\text{ A}/\mu\text{s}$ | - | 68 | - | nS |
| Q_{rr} | Reverse Recovery Charge | | - | 230 | - | nC |
| Dynamic Characteristics^b | | | | | | |
| C_{iss} | Input Capacitance | $V_{GS} = 0\text{ V}, V_{DS} = 75\text{ V}$ Frequency = 1 MHz | - | 4585 | - | pF |
| C_{oss} | Output Capacitance | | - | 333 | - | |
| C_{rss} | Reverse Transfer Capacitance | | - | 37 | - | |
| $t_d(on)$ | Turn-on Delay Time | $V_{DS} = 75\text{ V}, V_{GEN} = 10\text{ V},$ $R_G = 4.5\ \Omega, R_L = 2.5\ \Omega,$ $I_{DS} = 30\text{ A}$ | - | 24 | - | nS |
| t_r | Turn-on Rise Time | | - | 69 | - | |
| $t_d(off)$ | Turn-off Delay Time | | - | 50 | - | |
| t_f | Turn-off Fall Time | | - | 73 | - | |
| Gate Charge Characteristics^b | | | | | | |
| Q_g | Total Gate Charge | $V_{DS} = 75\text{ V}, V_{GS} = 10\text{ V},$ $I_{DS} = 30\text{ A}$ | - | 72 | - | nC |
| Q_{gs} | Gate-Source Charge | | - | 25 | - | |
| Q_{gd} | Gate-Drain Charge | | - | 15 | - | |

Notes :

a : Pulse test ; pulse width $\leq 300\ \mu\text{s}$, duty cycle $\leq 2\%$

b : Guaranteed by design, not subject to production testing

7. Typical Characteristics

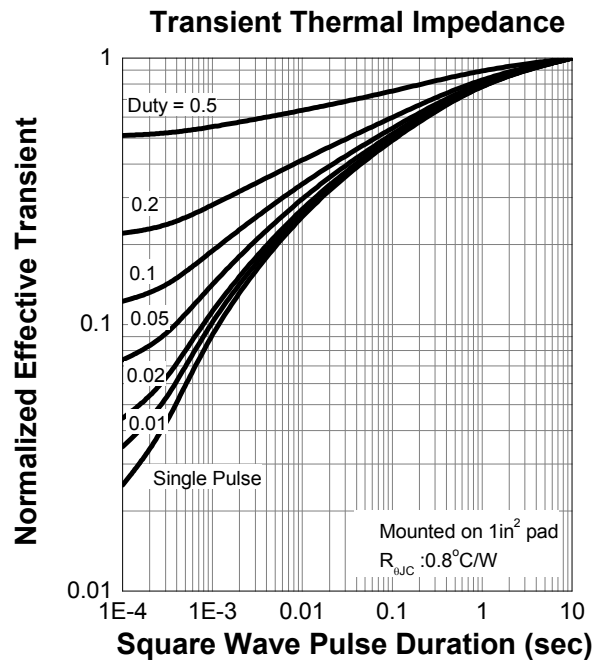
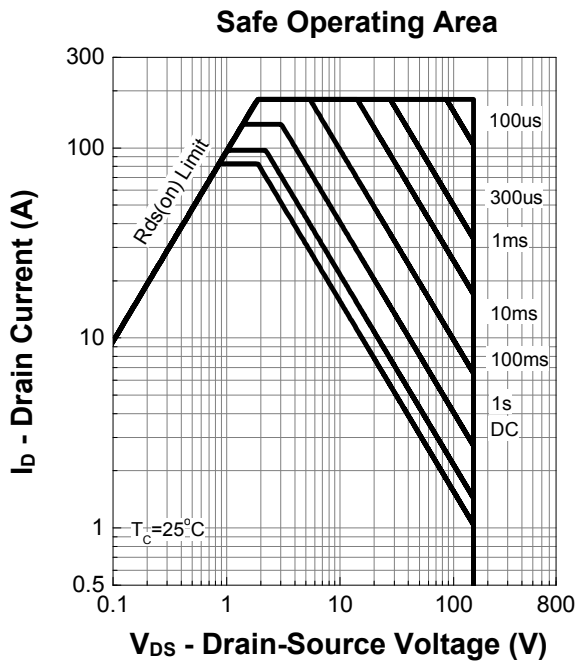
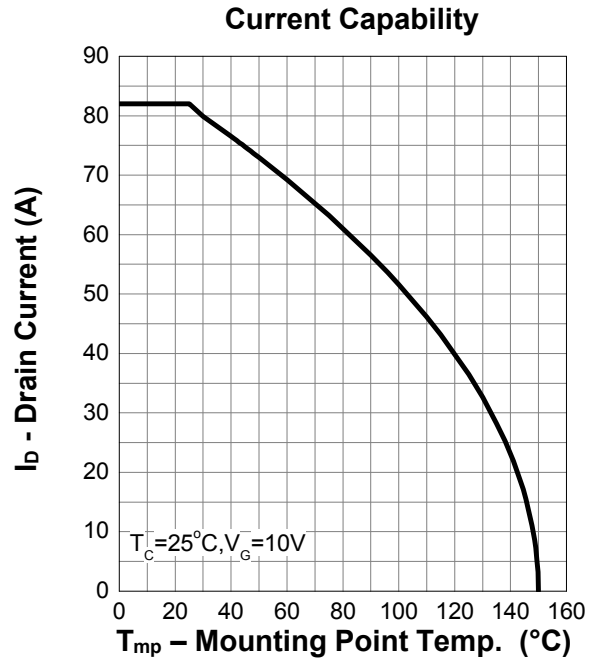
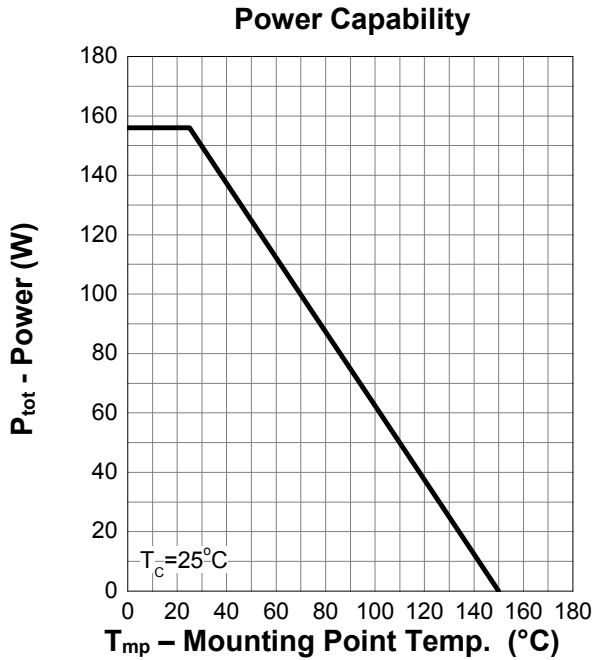

7. Typical Characteristics (cont.)

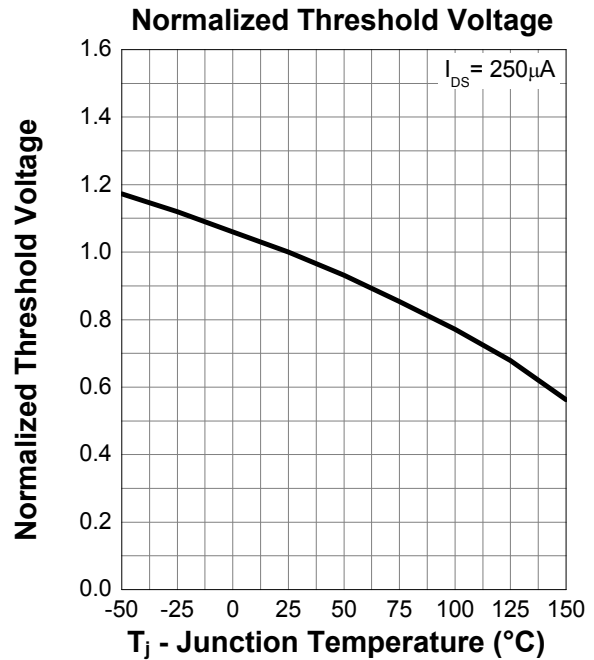
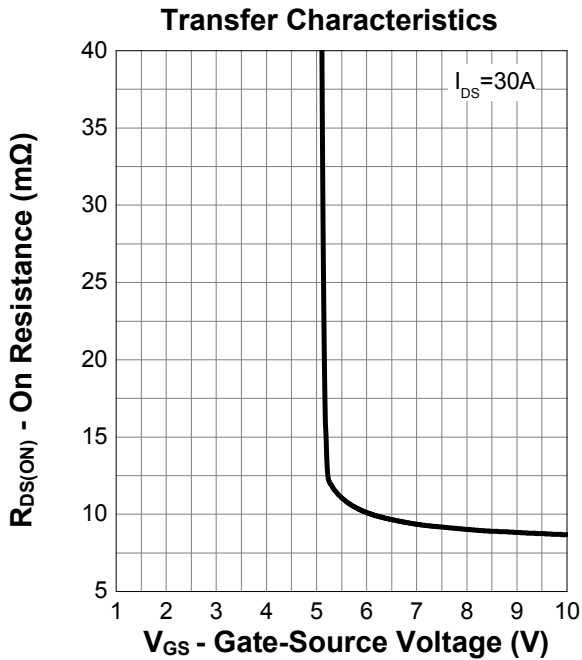
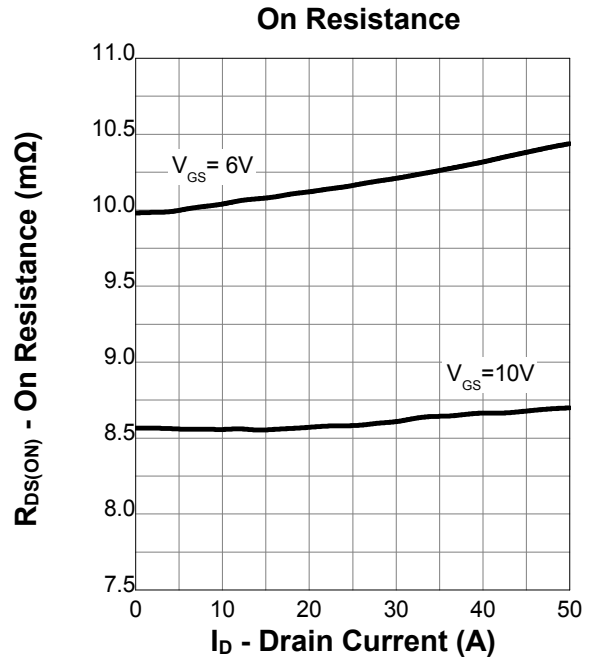
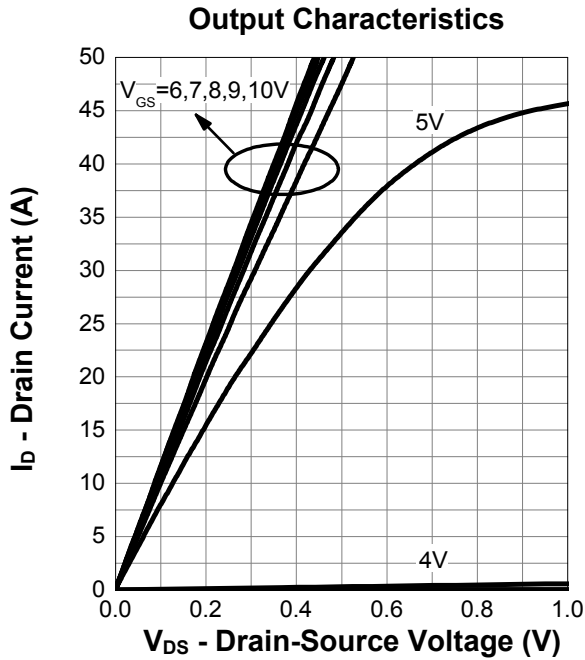

7. Typical Characteristics (cont.)

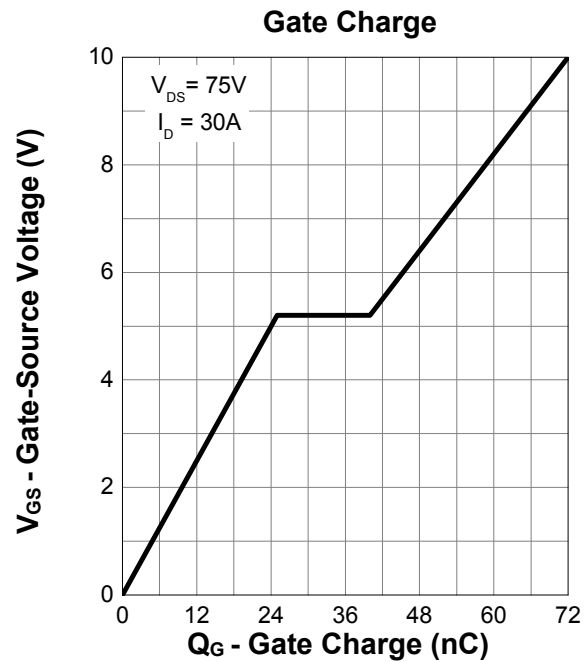
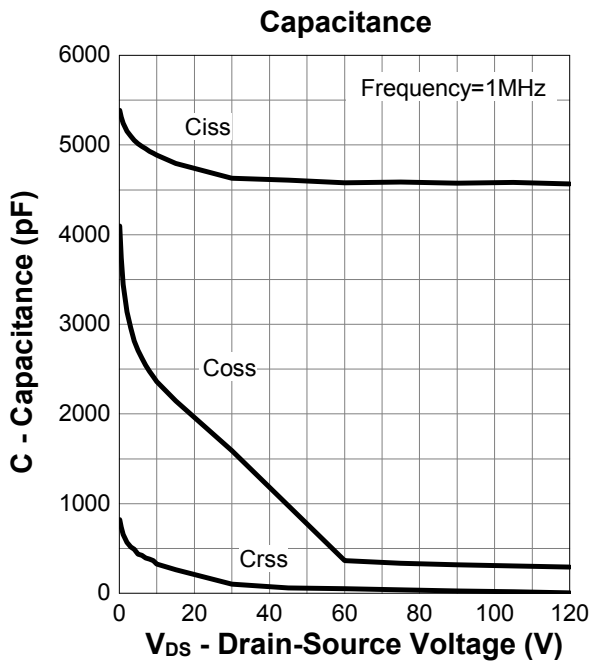
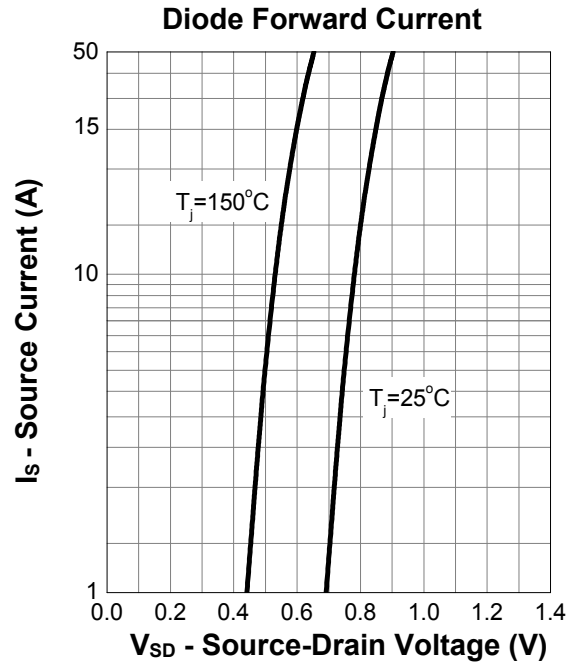
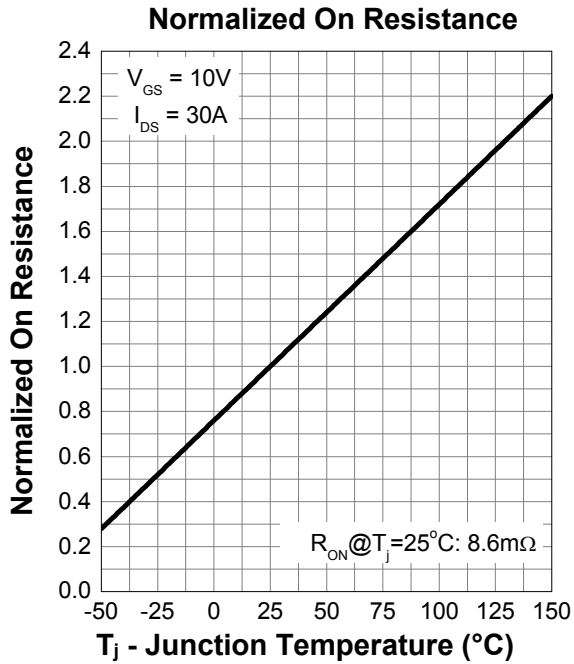

8.Package Dimensions

T0263-2L

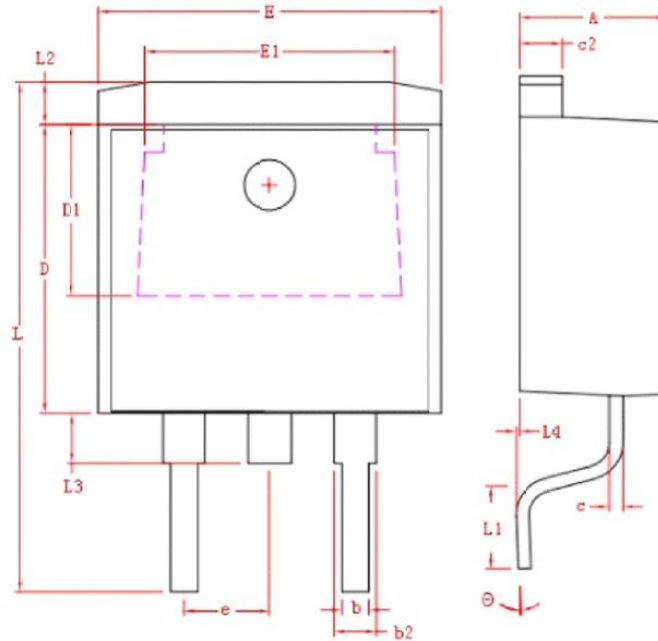

| Symbol | Dimensions In Millimeters | |
|----------|---------------------------|-------|
| | MIN. | MAX. |
| A | 4.40 | 4.80 |
| b | 0.76 | 1.00 |
| L4 | 0.00 | 0.25 |
| C | 0.36 | 0.50 |
| L3 | 1.50 REF | |
| L1 | 2.29 | 2.79 |
| E | 9.80 | 10.40 |
| E1 | 7.40 REF | |
| c2 | 1.25 | 1.45 |
| b2 | 1.17 | 1.47 |
| D | 8.60 | 9.00 |
| D1 | 5.10 REF | |
| e | 2.54 REF | |
| L | 14.6 | 15.8 |
| θ | $0^\circ \pm 3^\circ$ | |
| L2 | 1.27 REF | |