

N-Channel Enhancement Mode MOSFET

1. Product Information

1.1 Features

- Surface-mounted package
- ESD 2KV
- Advanced trench cell design

1.2 Applications

- LCD TV appliances
- LCDM appliances
- High power inverter system

1.3 Quick reference

- $BV \cong 60\text{ V}$
- $P_{tot} \cong 35\text{ W}$
- $I_D \cong 15\text{ A}$
- $R_{DS(ON)} \leq 80\text{m}\Omega @ V_{GS} = 10\text{ V}$
- $R_{DS(ON)} \leq 90\text{m}\Omega @ V_{GS} = 4.5\text{ V}$

2. Pin Description

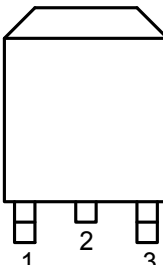
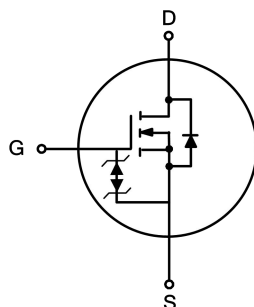
Pin	Description	Simplified Outline	Symbol
1	Gate(G)	 <p>Top View TO252</p>	
2	Drain(D)		
3	Source(S)		

3. Limiting Values

Symbol	Parameter	Conditions	Min	Max	Unit
V_{DS}	Drain-Source Voltage	$T_C = 25\text{ }^\circ\text{C}$	60	-	V
V_{GS}	Gate-Source Voltage	$T_C = 25\text{ }^\circ\text{C}$	-	± 20	V
I_D	Drain Current (DC)	$T_C = 25\text{ }^\circ\text{C}, V_{GS} = 10\text{ V}$	-	15	A
		$T_C = 100\text{ }^\circ\text{C}, V_{GS} = 10\text{ V}$	-	10	A
$I_{DM}^{*,***}$	Drain Current (Pulsed)	$T_C = 25\text{ }^\circ\text{C}, V_{GS} = 10\text{ V}$	-	40	A
P_{tot}	Drain power dissipation	$T_C = 25\text{ }^\circ\text{C}$	-	35	W
T_{stg}	Storage Temperature		-55	150	$^\circ\text{C}$
T_J	Junction Temperature		-	150	$^\circ\text{C}$
I_S	Continuous-Source Current	$T_C = 25\text{ }^\circ\text{C}$	-	15	A
$R_{\theta JA}^{**}$	Thermal Resistance- Junction to Ambient		-	50	$^\circ\text{C/W}$
$R_{\theta JC}^{**}$	Thermal Resistance- Junction to Case		-	3.5	

Notes :

- * Pulse width $\leq 300\text{ }\mu\text{s}$, duty cycle $\leq 2\%$
- ** Mounted on Large Heat Sink
- *** limited by bonding wire

4. Marking Information

Product Name	Marking
KJ15N06KE	<div style="display: inline-block; border: 1px solid black; padding: 2px;"> 15N06E YWWXXX </div> YWW: Date Code

5. Ordering Code

Product Name	Package	Reel Size	Tape width	Quantity	Note
KJ15N06KE	TO252			2500	

Note: KUAJIEXIN defines " Green " as lead-free (RoHS compliant) and halogen free (Br or Cl does not exceed 900 ppm by weight in homogeneous material and total of Br and Cl does not exceed 1500 ppm by weight; Follow IEC 61249-2-21 and IPC / JEDEC J-STD-020C)

6. Electrical Characteristics ($T_A=25^\circ$ Unless Otherwise Noted)

Symbol	Parameter	Conditions	Min	Typ	Max	Unit
Static Characteristics						
BV_{DSS}	Drain-Source Breakdown Voltage	$V_{GS} = 0\text{ V}, I_{DS} = 250\ \mu\text{A}$	60	-	-	V
$V_{GS(th)}$	Gate Threshold Voltage	$V_{DS} = V_{GS}, I_{DS} = 250\ \mu\text{A}$	1.0	-	2.0	V
I_{DSS}	Drain Leakage Current	$V_{DS} = 48\text{ V}, V_{GS} = 0\text{ V}$	-	-	1	μA
I_{GSS}	Gate Leakage Current	$V_{GS} = 0\text{ V}, V_{GS} = \pm 20\text{ V}$	-	-	± 100	nA
$R_{DS(ON)}^a$	On-State Resistance	$V_{GS} = 10\text{ V}, I_{DS} = 6\text{ A}$	-	75	80	m Ω
		$V_{GS} = 4.5\text{ V}, I_{DS} = 4\text{ A}$	-	80	90	
Diode Characteristics						
V_{SD}^a	Diode Forward Voltage	$I_{SD} = 6\text{ A}, V_{GS} = 0\text{ V}$	-	-	1.3	V
t_{rr}	Reverse Recovery Time	$I_{DS} = 6\text{ A}, V_{GS} = 0\text{ V}$ $di_{SD}/dt = 100\text{ A}/\mu\text{s}$	-	26	-	nS
Q_{rr}	Reverse Recovery Charge		-	2.8	-	μC
Dynamic Characteristics ^b						
C_{iss}	Input Capacitance	$V_{GS} = 0\text{ V}, V_{DS} = 30\text{ V}$ Frequency = 1 MHz	-	351	-	pF
C_{oss}	Output Capacitance		-	28	-	
C_{rss}	Reverse Transfer Capacitance		-	26	-	
$t_d(on)$	Turn-on Delay Time	$V_{DS} = 30\text{ V}, V_{GEN} = 10\text{ V},$ $R_G = 4.5\ \Omega, R_L = 5\ \Omega,$ $I_{DS} = 6\text{ A}$	-	5	-	nS
t_r	Turn-on Rise Time		-	21	-	
$t_d(off)$	Turn-off Delay Time		-	15	-	
t_f	Turn-off Fall Time		-	23	-	
Gate Charge Characteristics ^b						
Q_g	Total Gate Charge	$V_{DS} = 30\text{ V}, V_{GS} = 10\text{ V},$ $I_{DS} = 6\text{ A}$	-	12	-	nC
Q_{gs}	Gate-Source Charge		-	3	-	
Q_{gd}	Gate-Drain Charge		-	1.5	-	

Notes :

a : Pulse test ; pulse width $\leq 300\ \mu\text{s}$, duty cycle $\leq 2\%$

b : Guaranteed by design, not subject to production testing

7. Typical Characteristics

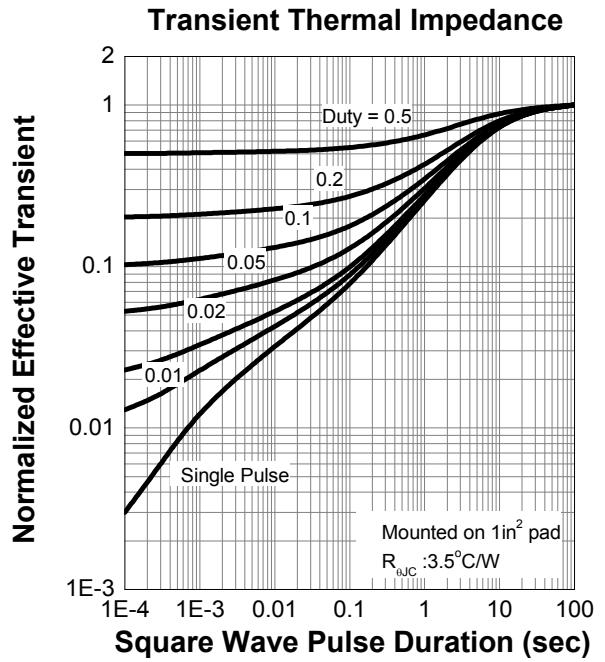
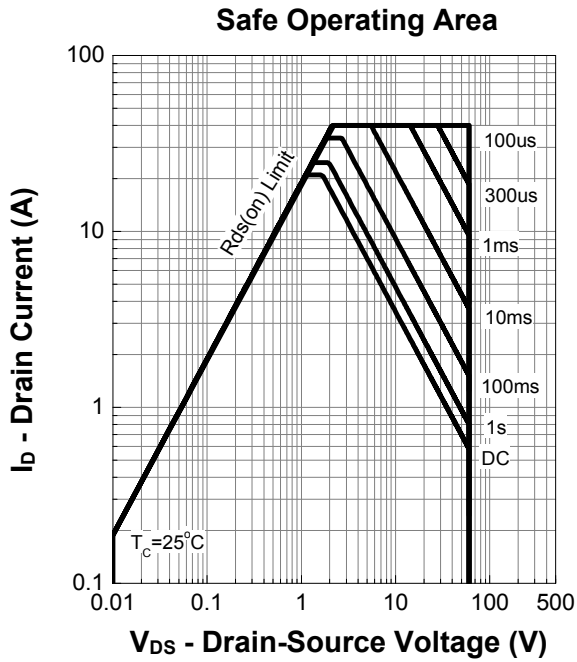
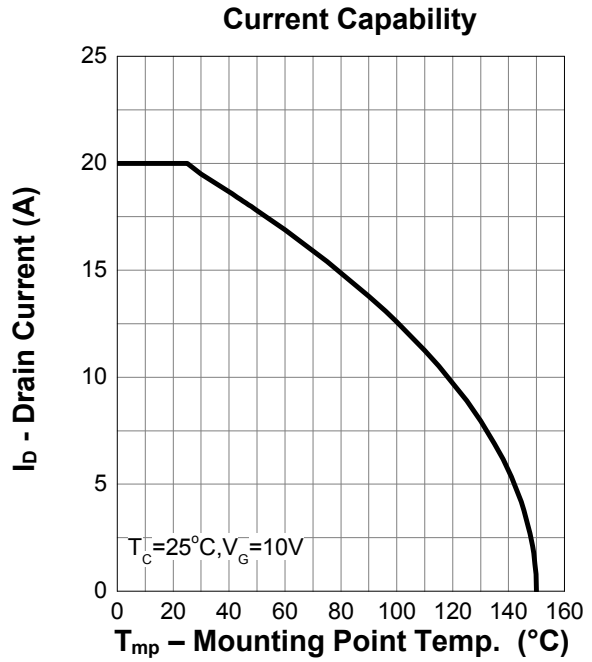
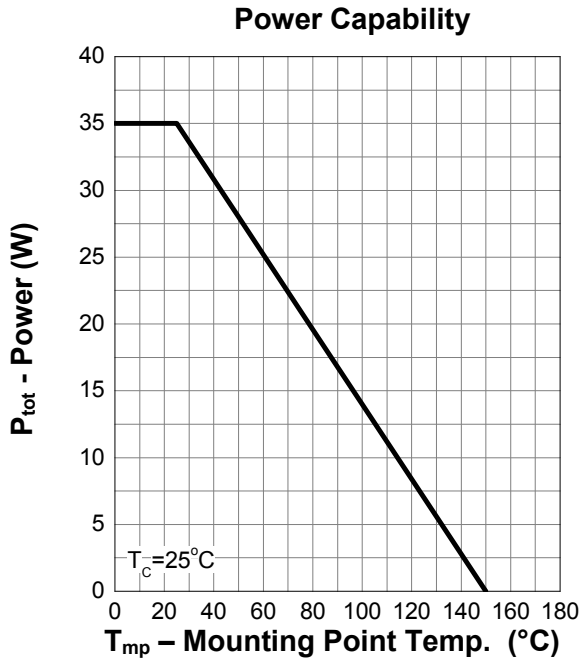

7. Typical Characteristics (cont.)

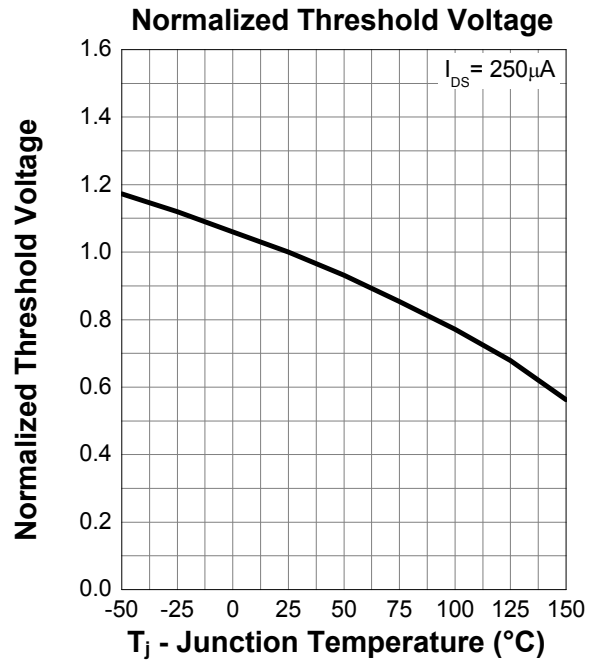
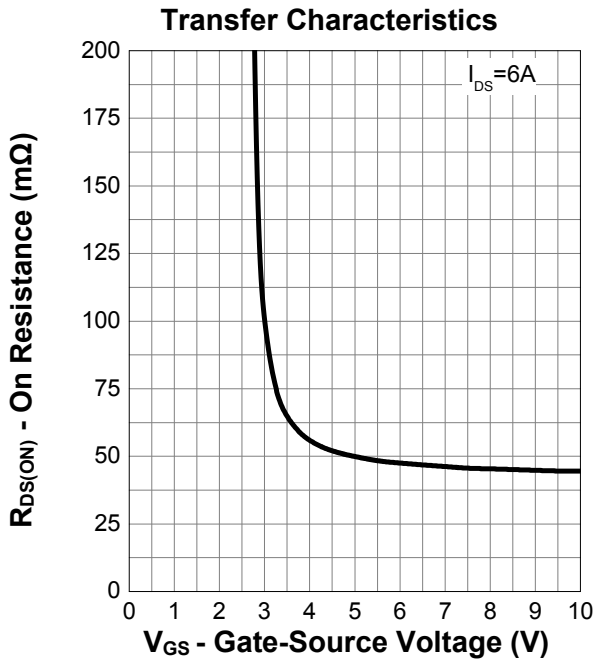
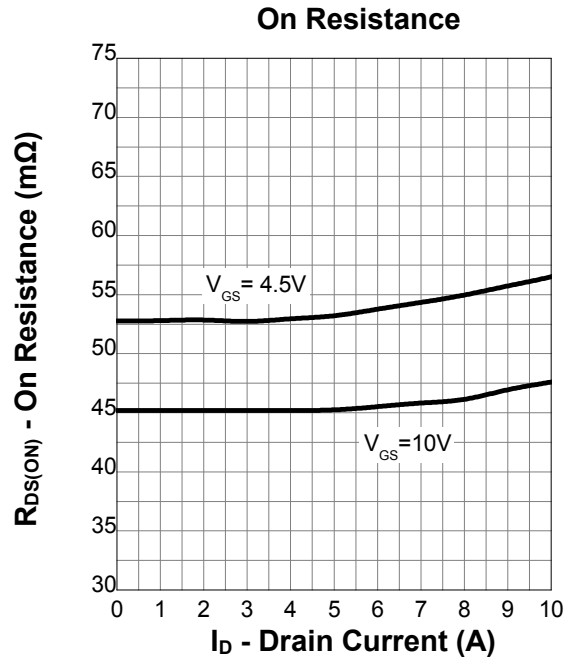
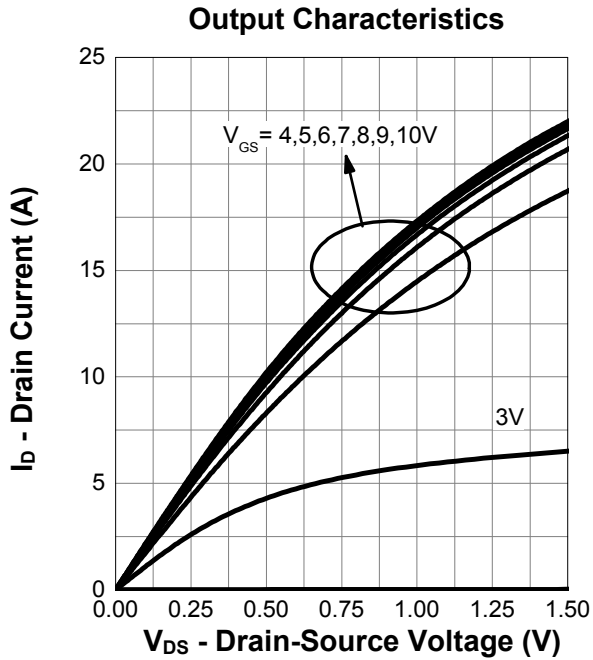

7. Typical Characteristics (cont.)

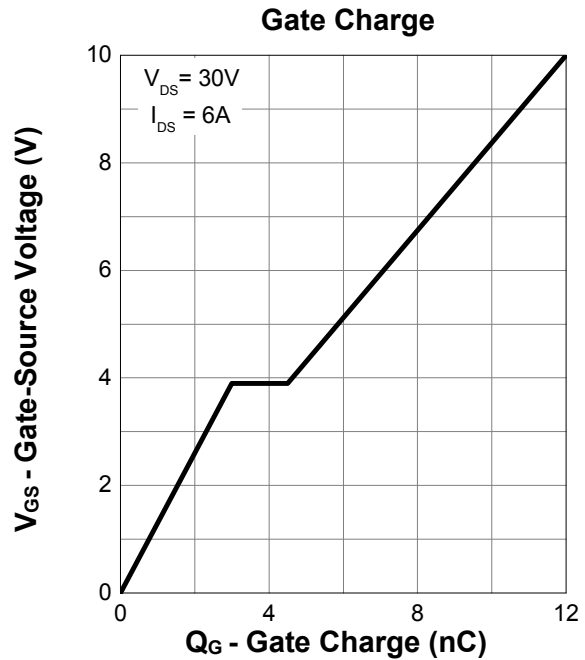
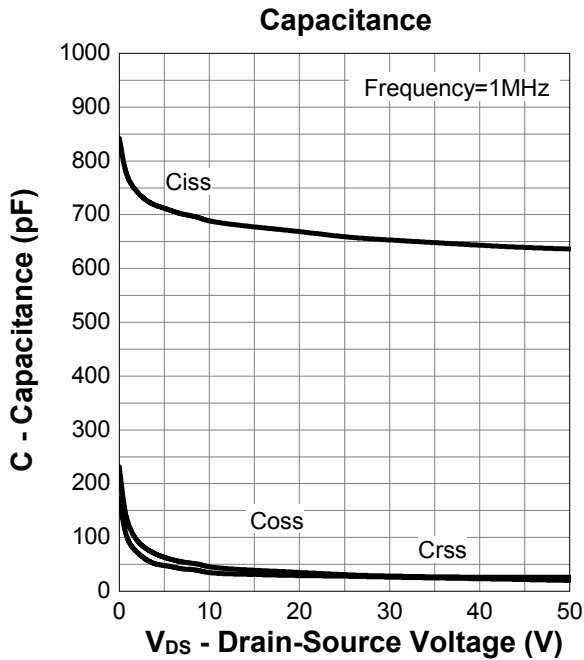
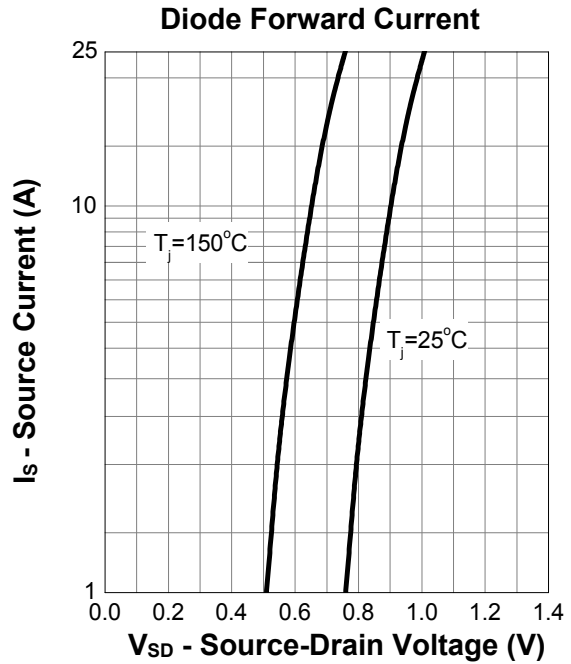
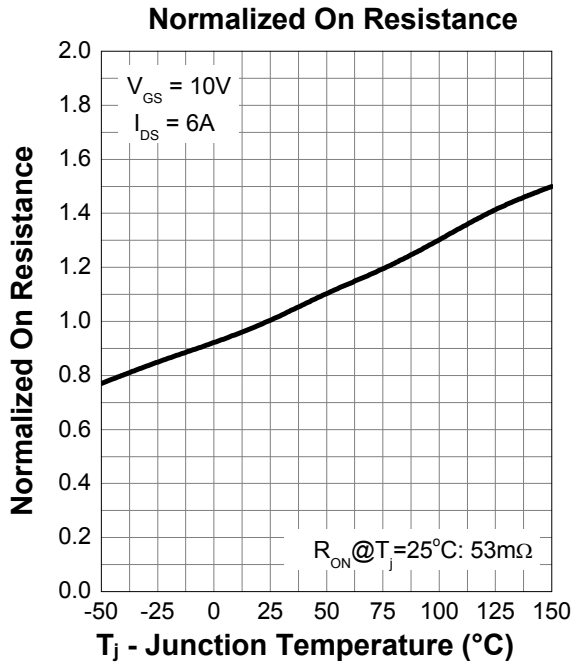

8.Package Dimensions

T0252-3L

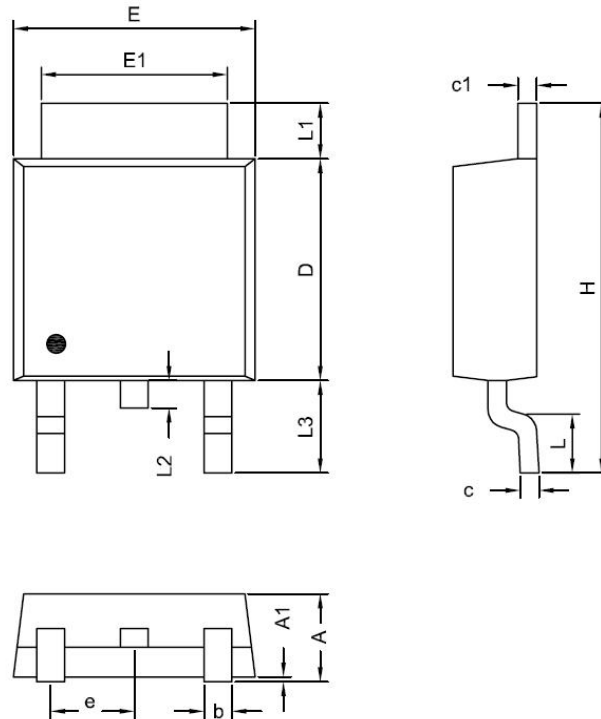

Symbol	Dimensions In Millimeters	
	MIN.	MAX.
A	2.19	2.38
A1	0.02	0.13
D	5.30	6.40
E	6.35	6.80
E1	5.20	5.50
c	0.40	0.60
c1	0.40	0.60
b	0.55	0.85
e	2.30 BCS	
L	1.00	1.80
L1	0.70	1.80
L2	0.70 BCS	
L3	2.40	2.80
H	9.20	10.40