

# N-Channel Enhancement Mode MOSFET

## 1. Product Information

### 1.1 Features

- Surface-mounted package
- Advanced trench cell design

### 1.2 Applications

- LCD TV appliances
- High power inverter system
- LCDM appliances

### 1.3 Quick reference

- $BV \geq 60\text{ V}$
- $R_{DS(ON)} \leq 50\text{m}\Omega @ V_{GS} = 10\text{ V}$
- $P_{tot} \leq 35\text{ W}$
- $R_{DS(ON)} \leq 58\text{m}\Omega @ V_{GS} = 4.5\text{ V}$
- $I_D \leq 25\text{ A}$

## 2. Pin Description

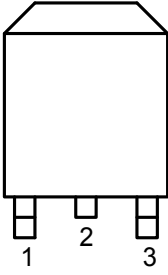
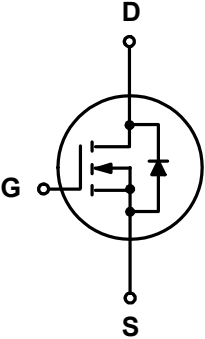
Pin	Description	Simplified Outline	Symbol
1	Gate(G)	 Top View TO-252	
2	Drain(D)		
3	Source(S)		

### 3. Limiting Values

Symbol	Parameter	Conditions	Min	Max	Unit
V <sub>DS</sub>	Drain-Source Voltage	T <sub>C</sub> = 25 °C	60	-	V
V <sub>GS</sub>	Gate-Source Voltage	T <sub>C</sub> = 25 °C	-	±20	V
I <sub>D</sub>	Drain Current ( DC )	T <sub>C</sub> = 25 °C, V <sub>GS</sub> = 10 V	-	25	A
		T <sub>C</sub> = 100 °C, V <sub>GS</sub> = 10 V	-	15	A
I <sub>DM</sub> <sup>*,***</sup>	Drain Current ( Pulsed )	T <sub>C</sub> = 25 °C, V <sub>GS</sub> = 10 V	-	40	A
P <sub>tot</sub>	Drain power dissipation	T <sub>C</sub> = 25 °C	-	35	W
T <sub>stg</sub>	Storage Temperature		-55	150	°C
T <sub>J</sub>	Junction Temperature		-	150	°C
I <sub>S</sub>	Continuous-Source Current	T <sub>C</sub> = 25 °C	-	25	A
R <sub>θJA</sub> <sup>**</sup>	Thermal Resistance- Junction to Ambient		-	50	°C/W
R <sub>θJC</sub> <sup>**</sup>	Thermal Resistance- Junction to Case		-	3.5	

Notes :

- \* Pulse width ≤ 300 μs, duty cycle ≤ 2 %
- \*\* Mounted on Large Heat Sink
- \*\*\* limited by bonding wire

### 4. Marking Information

Product Name	Marking
KJ25N06K	<div style="display: inline-block; border: 1px solid black; padding: 2px;"> <b>25N06</b>  <b>YWWXXX</b> </div> <b>YWW:</b> <b>Date Code</b>

### 5. Ordering Code

Product Name	Package	Reel Size	Tape width	Quantity	Note
KJ25N06K	TO252			2500	

Note: KUAJIEXIN defines “ Green ” as lead-free ( RoHS compliant ) and halogen free ( Br or Cl does not exceed 900 ppm by weight in homogeneous material and total of Br and Cl does not exceed 1500 ppm by weight; Follow IEC 61249-2-21 and IPC / JEDEC J-STD-020C )

**6. Electrical Characteristics** (  $T_A=25^\circ$  Unless Otherwise Noted )

Symbol	Parameter	Conditions	Min	Typ	Max	Unit
<b>Static Characteristics</b>						
$BV_{DSS}$	Drain-Source Breakdown Voltage	$V_{GS} = 0\text{ V}, I_{DS} = 250\ \mu\text{A}$	60	-	-	V
$V_{GS(th)}$	Gate Threshold Voltage	$V_{DS} = V_{GS}, I_{DS} = 250\ \mu\text{A}$	1.0	-	2.0	V
$I_{DSS}$	Drain Leakage Current	$V_{DS} = 48\text{ V}, V_{GS} = 0\text{ V}$	-	-	1	$\mu\text{A}$
$I_{GSS}$	Gate Leakage Current	$V_{GS} = 0\text{ V}, V_{GS} = \pm 20\text{ V}$	-	-	$\pm 100$	nA
$R_{DS(ON)}^a$	On-State Resistance	$V_{GS} = 10\text{ V}, I_{DS} = 6\text{ A}$	-	45	50	m $\Omega$
		$V_{GS} = 4.5\text{ V}, I_{DS} = 4\text{ A}$	-	50	58	
<b>Diode Characteristics</b>						
$V_{SD}^a$	Diode Forward Voltage	$I_{SD} = 6\text{ A}, V_{GS} = 0\text{ V}$	-	-	1.3	V
$t_{rr}$	Reverse Recovery Time	$I_{DS} = 6\text{ A}, V_{GS} = 0\text{ V}$ $di_{SD}/dt = 100\text{ A}/\mu\text{s}$	-	26	-	nS
$Q_{rr}$	Reverse Recovery Charge		-	2.8	-	$\mu\text{C}$
<b>Dynamic Characteristics<sup>b</sup></b>						
$C_{iss}$	Input Capacitance	$V_{GS} = 0\text{ V}, V_{DS} = 30\text{ V}$ Frequency = 1 MHz	-	651	-	pF
$C_{oss}$	Output Capacitance		-	28	-	
$C_{rss}$	Reverse Transfer Capacitance		-	26	-	
$t_d(on)$	Turn-on Delay Time	$V_{DS} = 30\text{ V}, V_{GEN} = 10\text{ V},$ $R_G = 4.5\ \Omega, R_L = 5\ \Omega,$ $I_{DS} = 6\text{ A}$	-	5	-	nS
$t_r$	Turn-on Rise Time		-	21	-	
$t_d(off)$	Turn-off Delay Time		-	15	-	
$t_f$	Turn-off Fall Time		-	23	-	
<b>Gate Charge Characteristics<sup>b</sup></b>						
$Q_g$	Total Gate Charge	$V_{DS} = 30\text{ V}, V_{GS} = 10\text{ V},$ $I_{DS} = 6\text{ A}$	-	12	-	nC
$Q_{gs}$	Gate-Source Charge		-	3	-	
$Q_{gd}$	Gate-Drain Charge		-	1.5	-	

Notes :

a : Pulse test ; pulse width  $\leq 300\ \mu\text{s}$ , duty cycle  $\leq 2\%$ 

b : Guaranteed by design, not subject to production testing

## 7. Typical Characteristics

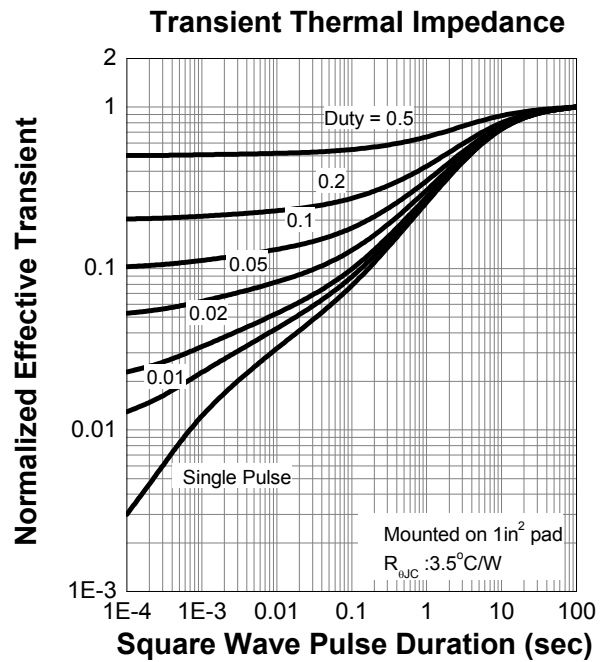
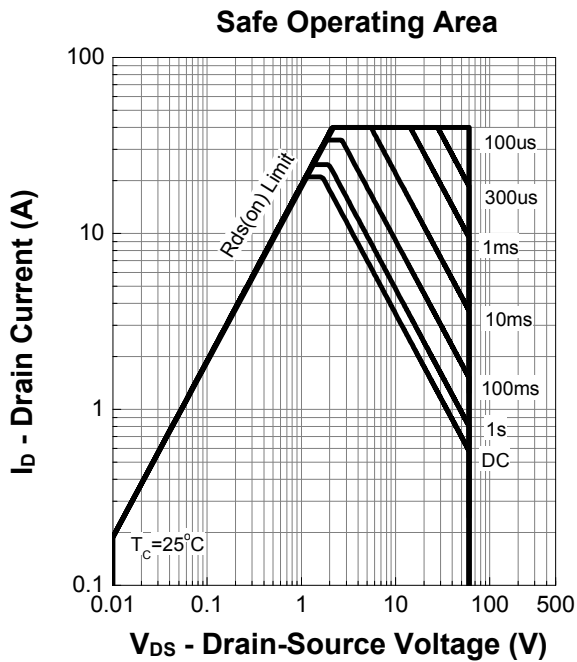
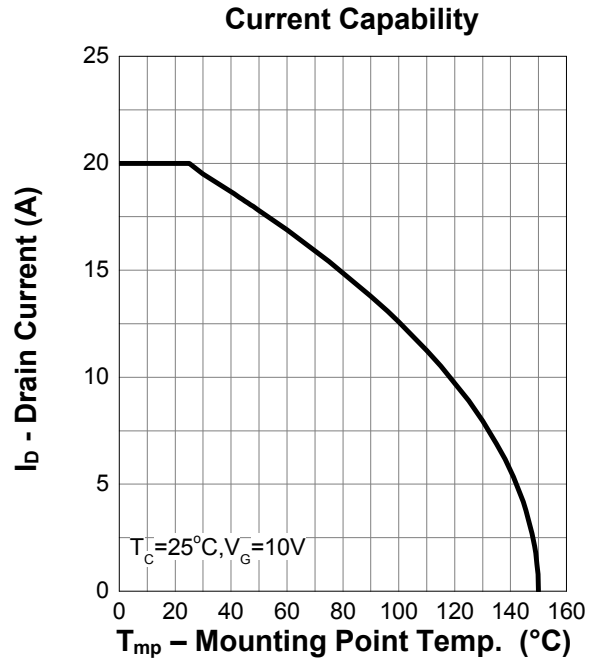
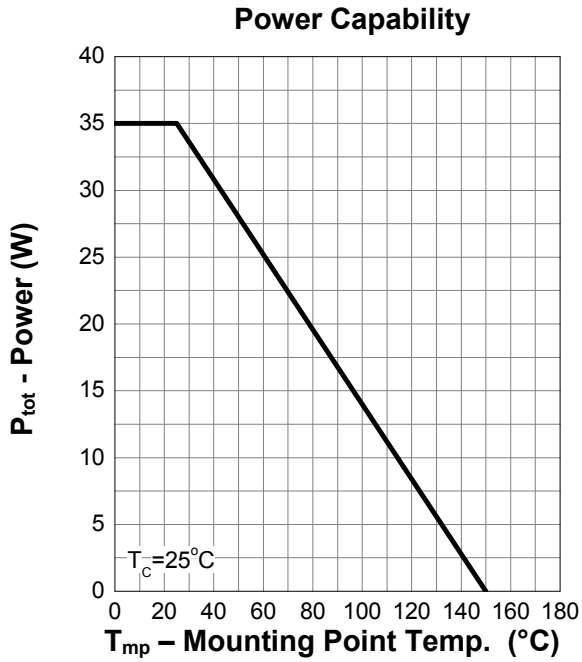

## 7. Typical Characteristics (cont.)

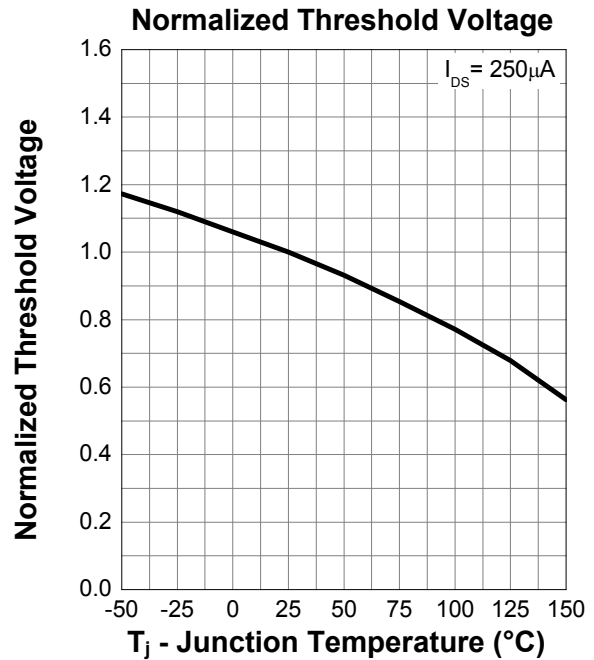
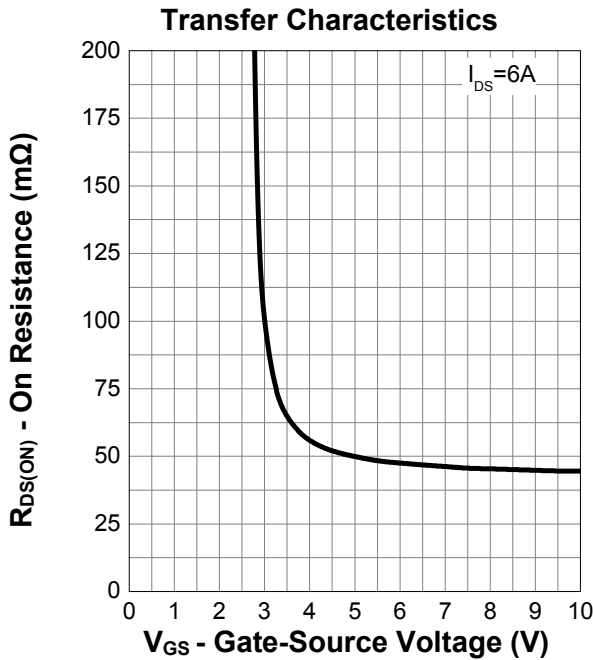
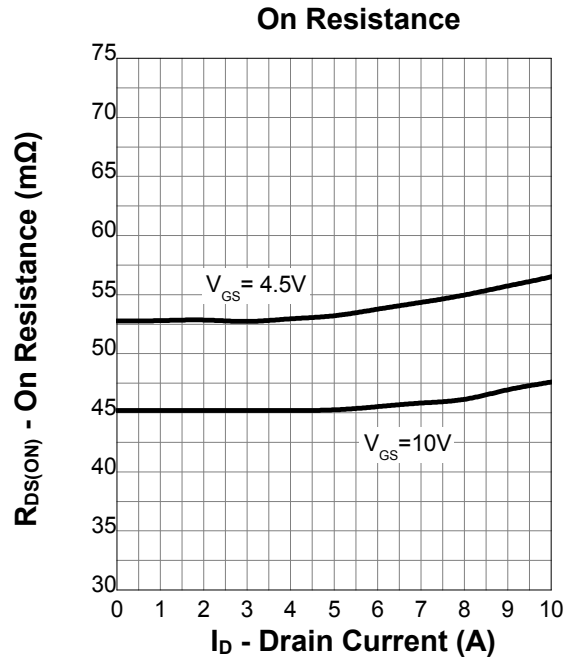
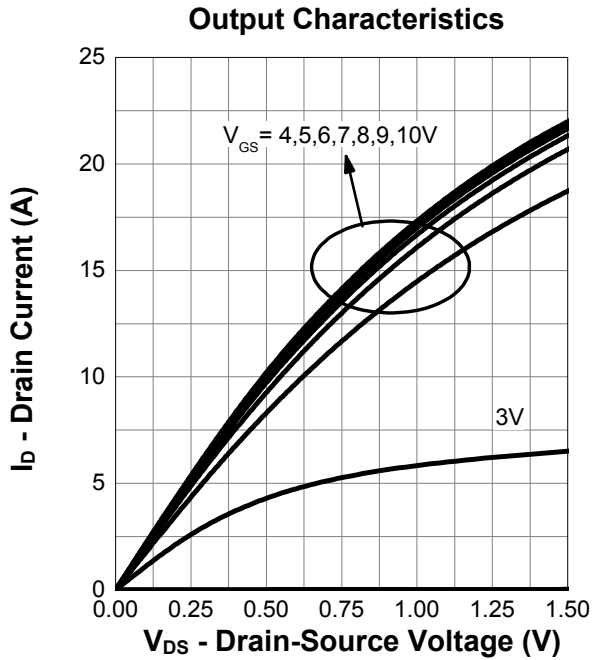

## 7. Typical Characteristics (cont.)

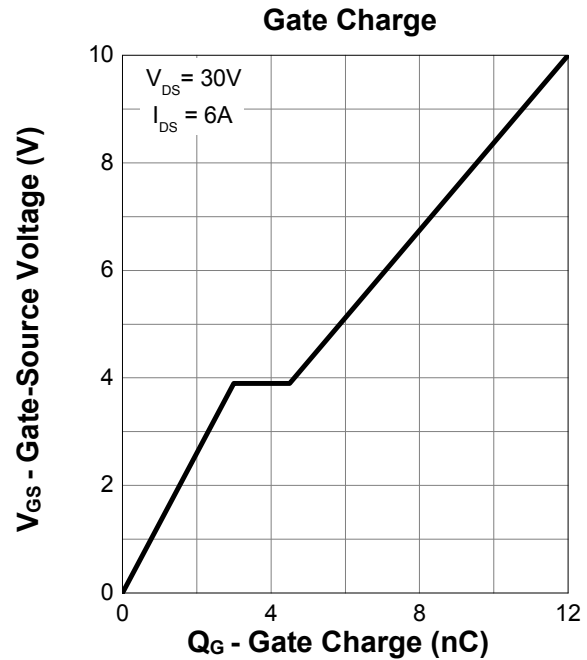
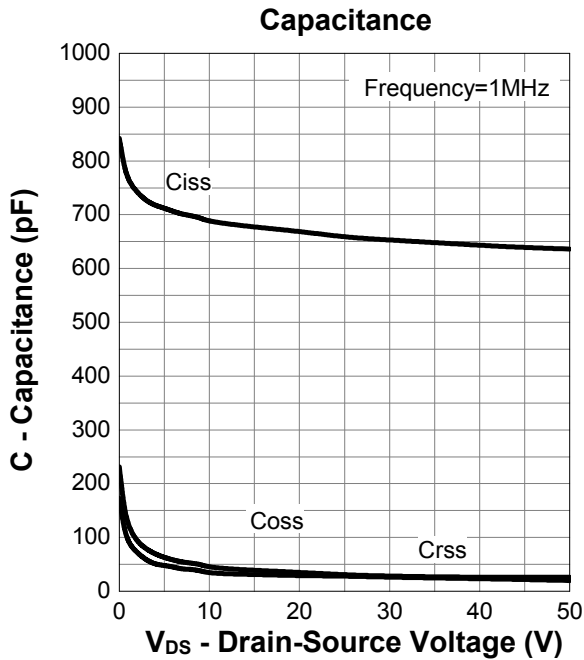
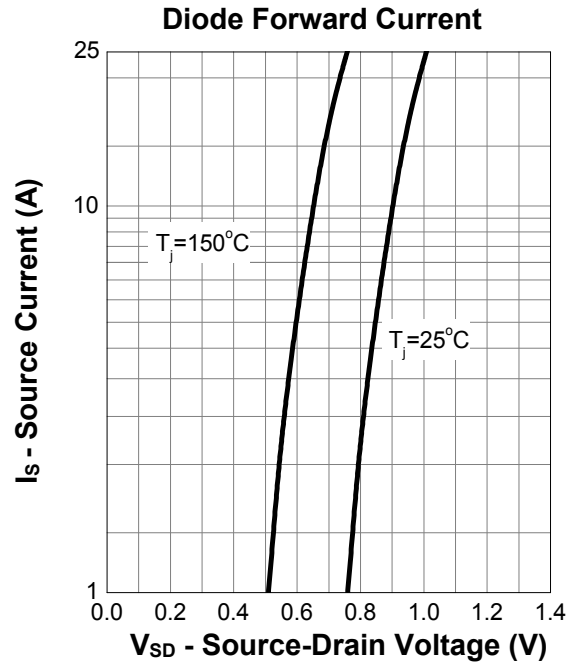
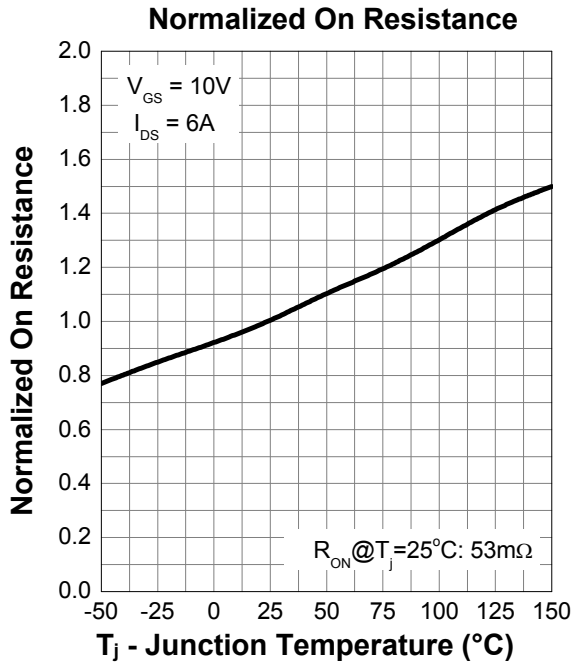

## 8.Package Dimensions

T0252-3L

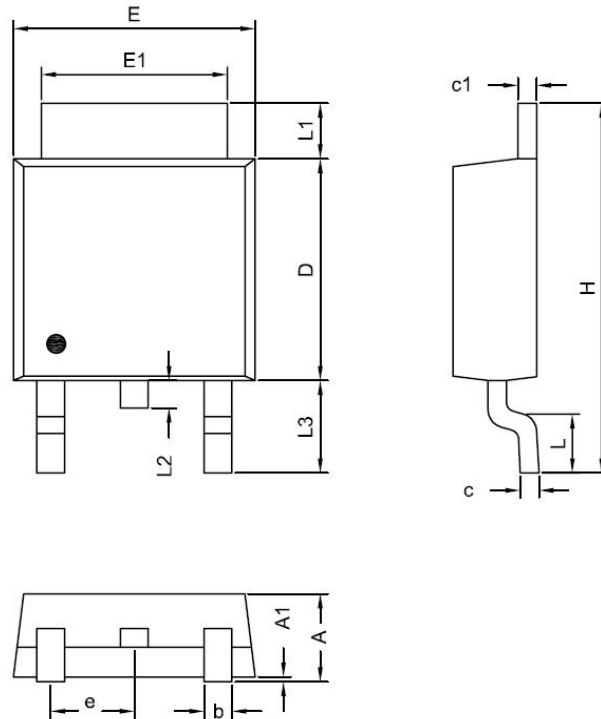

Symbol	Dimensions In Millimeters	
	MIN.	MAX.
A	2.19	2.38
A1	0.02	0.13
D	5.30	6.40
E	6.35	6.80
E1	5.20	5.50
c	0.40	0.60
c1	0.40	0.60
b	0.55	0.85
e	2.30 BCS	
L	1.00	1.80
L1	0.70	1.80
L2	0.70 BCS	
L3	2.40	2.80
H	9.20	10.40