

N-Channel Enhancement Mode MOSFET

1. Product Information

1.1 Features

- Surface-mounted package
- Advanced trench cell design

1.2 Applications

- LCD TV appliances
- High power inverter system
- LCDM appliances

1.3 Quick reference

- $BV \cong 60\text{ V}$
- $R_{DS(ON)} \leq 22\text{ m}\Omega @ V_{GS} = 10\text{ V}$
- $P_{tot} \leq 50\text{ W}$
- $R_{DS(ON)} \leq 28\text{ m}\Omega @ V_{GS} = 4.5\text{ V}$
- $I_D \leq 45\text{ A}$

2. Pin Description

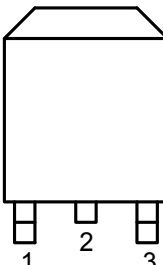
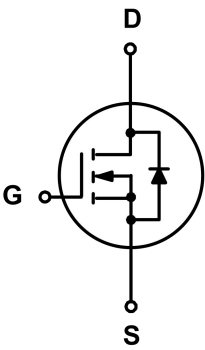
Pin	Description	Simplified Outline	Symbol
1	Gate(G)	 <p>Top View TO-252</p>	
2	Drain(D)		
3	Source(S)		

3. Limiting Values

Symbol	Parameter	Conditions	Min	Max	Unit
V _{DS}	Drain-Source Voltage	T _C = 25 °C	-	60	V
V _{GS}	Gate-Source Voltage	T _C = 25 °C	-	±20	V
I _D *	Drain Current (DC)	T _C = 25 °C, V _{GS} = 10 V	-	45	A
		T _C = 100 °C, V _{GS} = 10 V	-	23	A
I _{DM} *,***	Drain Current (Pulsed)	T _C = 25 °C, V _{GS} = 10 V	-	96	A
P _{tot}	Drain power dissipation	T _C = 25 °C	-	50	W
T _{stg}	Storage Temperature		-55	150	°C
T _J	Junction Temperature		-	150	°C
I _S	Continuous-Source Current	T _C = 25 °C	-	45	A
R _{θJA} **	Thermal Resistance- Junction to Ambient		-	50	°C/W
R _{θJC} **	Thermal Resistance- Junction to Case		-	2.5	

Notes :

- * Pulse width ≤ 300 μs, duty cycle ≤ 2 %
- ** Mounted on Large Heat Sink
- *** limited by bonding wire

4. Marking Information

Product Name	Marking
KJ45N06K	<div style="display: flex; align-items: center;"> <div style="background-color: black; color: white; padding: 5px; margin-right: 10px;"> 45N06 YWWXXX </div> <div> YWW: Date Code </div> </div>

5. Ordering Code

Product Name	Package	Reel Size	Tape width	Quantity	Note
KJ45N06K	TO-252			2500	

Note: KUAJIEXIN defines “ Green ” as lead-free (RoHS compliant) and halogen free (Br or Cl does not exceed 900 ppm by weight in homogeneous material and total of Br and Cl does not exceed 1500 ppm by weight; Follow IEC 61249-2-21 and IPC / JEDEC J-STD-020C)

6. Electrical Characteristics ($T_A=25^\circ$ Unless Otherwise Noted)

Symbol	Parameter	Conditions	Min	Typ	Max	Unit
Static Characteristics						
BV_{DSS}	Drain-Source Breakdown Voltage	$V_{GS} = 0\text{ V}, I_{DS} = 250\ \mu\text{A}$	60	-	-	V
$V_{GS(th)}$	Gate Threshold Voltage	$V_{DS} = V_{GS}, I_{DS} = 250\ \mu\text{A}$	1.0	-	2.5	V
I_{DSS}	Drain Leakage Current	$V_{DS} = 48\text{ V}, V_{GS} = 0\text{ V}$	-	-	1	μA
I_{GSS}	Gate Leakage Current	$V_{GS} = 0\text{ V}, V_{GS} = \pm 20\text{ V}$	-	-	± 10	μA
$R_{DS(ON)}^a$	On-State Resistance	$V_{GS} = 10\text{ V}, I_{DS} = 20\text{ A}$	-	19.5	22	m Ω
		$V_{GS} = 4.5\text{ V}, I_{DS} = 10\text{ A}$	-	23.5	28	
Diode Characteristics						
V_{SD}^a	Diode Forward Voltage	$I_{SD} = 20\text{ A}, V_{GS} = 0\text{ V}$	-	-	1.3	V
t_{rr}	Reverse Recovery Time	$I_{DS} = 20\text{ A}, V_{GS} = 0\text{ V}$ $di_{SD}/dt = 100\text{ A}/\mu\text{s}$	-	15.3	-	nS
Q_{rr}	Reverse Recovery Charge		-	12.9	-	nC
Dynamic Characteristics ^b						
C_{iss}	Input Capacitance	$V_{GS} = 0\text{ V}, V_{DS} = 30\text{ V}$ Frequency = 1 MHz	-	1559	-	pF
C_{oss}	Output Capacitance		-	60	-	
C_{rSS}	Reverse Transfer Capacitance		-	50	-	
$t_d(on)$	Turn-on Delay Time	$V_{DS} = 30\text{ V}, V_{GEN} = 10\text{ V},$ $R_G = 4.5\ \Omega, R_L = 1.5\ \Omega,$ $I_{DS} = 20\text{ A}$	-	7	-	nS
t_r	Turn-on Rise Time		-	32	-	
$t_d(off)$	Turn-off Delay Time		-	29	-	
t_f	Turn-off Fall Time		-	45	-	
Gate Charge Characteristics ^b						
Q_g	Total Gate Charge	$V_{DS} = 30\text{ V}, V_{GS} = 10\text{ V},$ $I_{DS} = 20\text{ A}$	-	26.9	-	nC
Q_{gs}	Gate-Source Charge		-	6.7	-	
Q_{gd}	Gate-Drain Charge		-	3.9	-	

Notes :

a : Pulse test ; pulse width $\leq 300\ \mu\text{s}$, duty cycle $\leq 2\%$

b : Guaranteed by design, not subject to production testing

7. Typical Characteristics

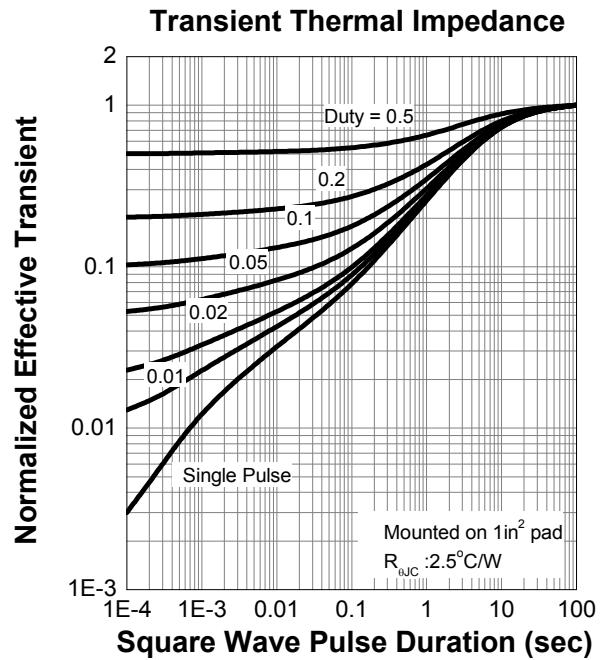
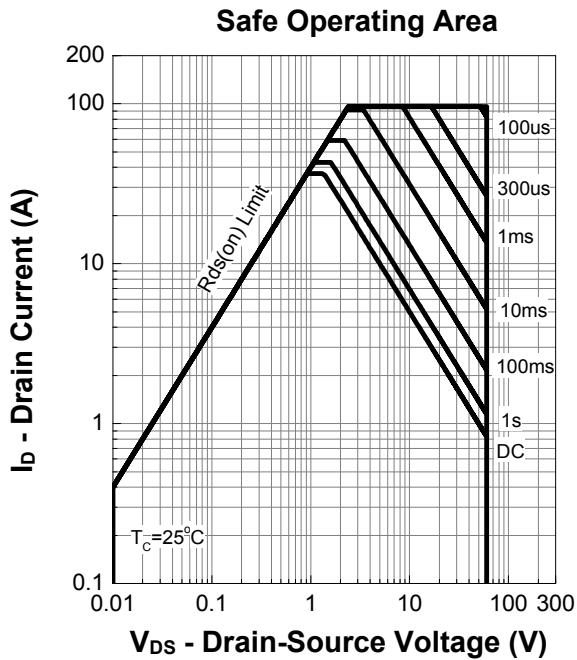
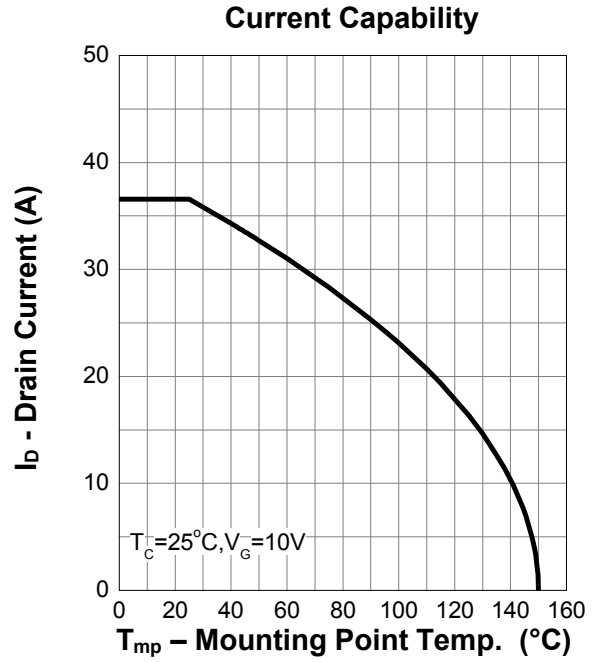
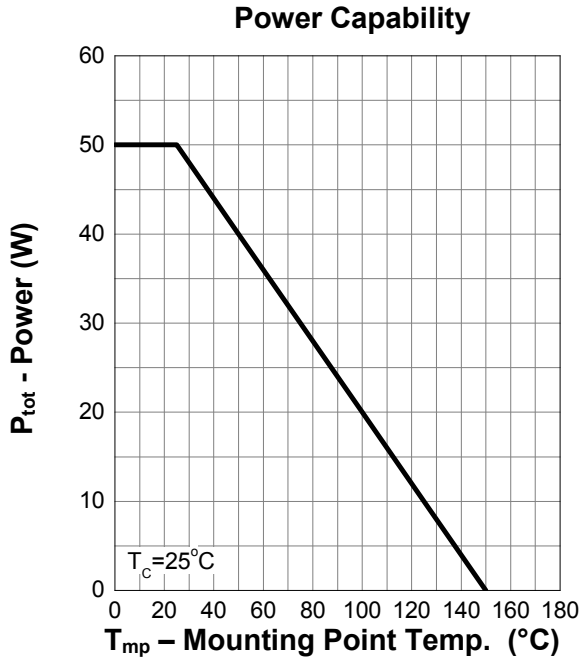

7. Typical Characteristics (cont.)

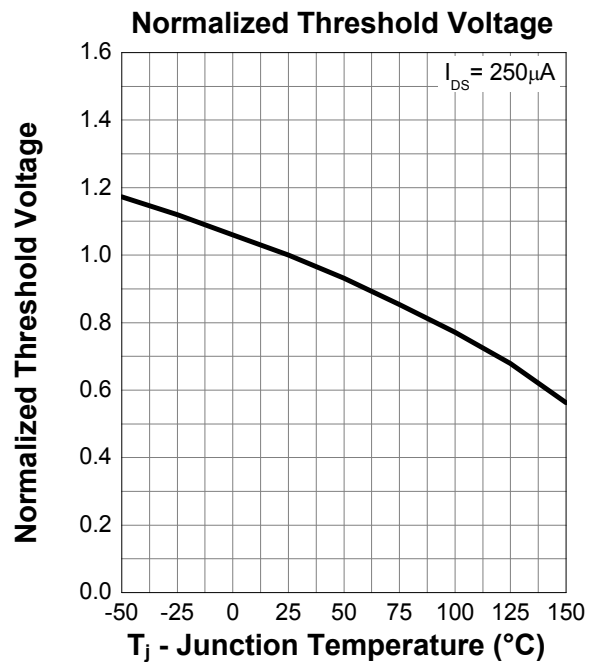
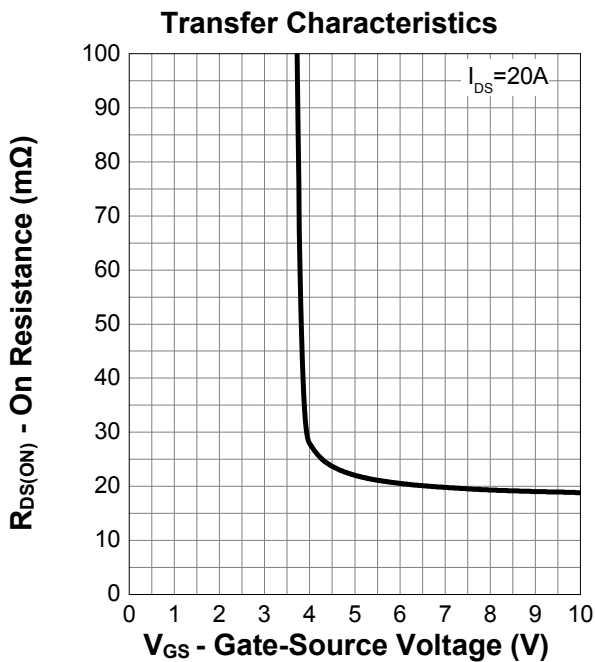
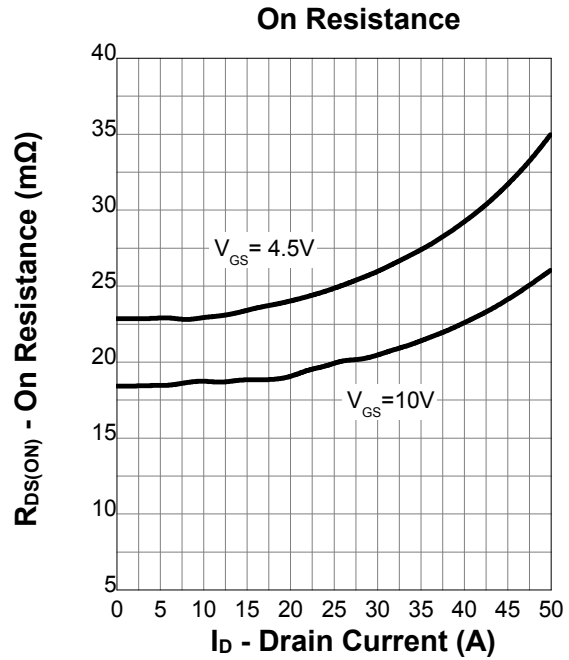
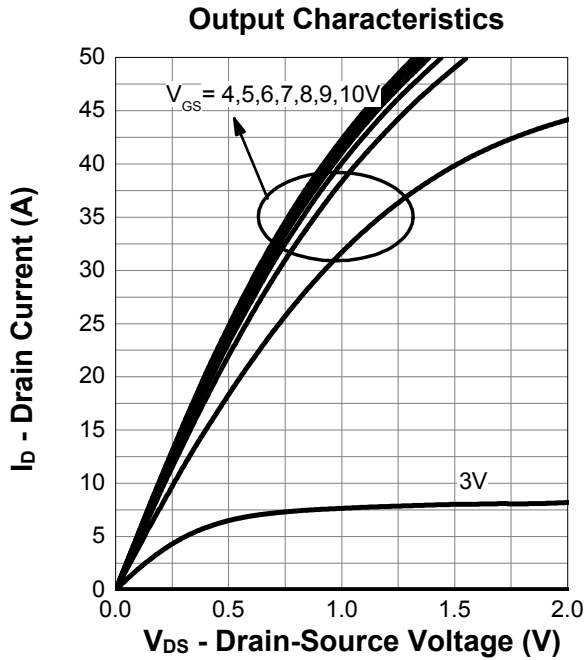

7. Typical Characteristics (cont.)

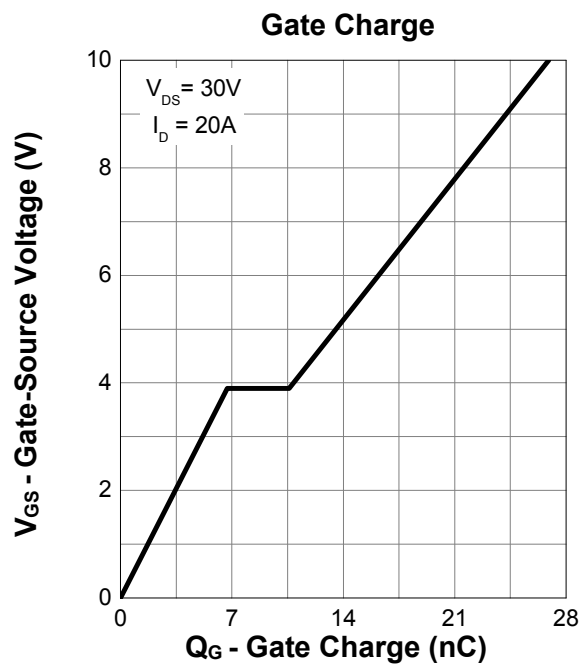
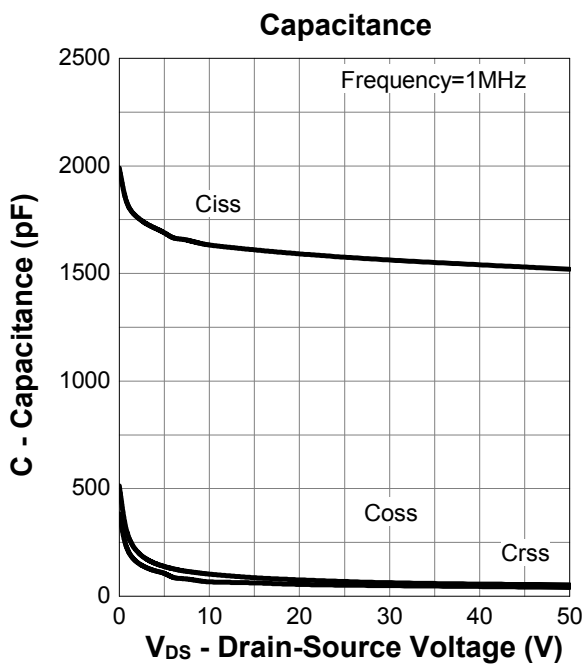
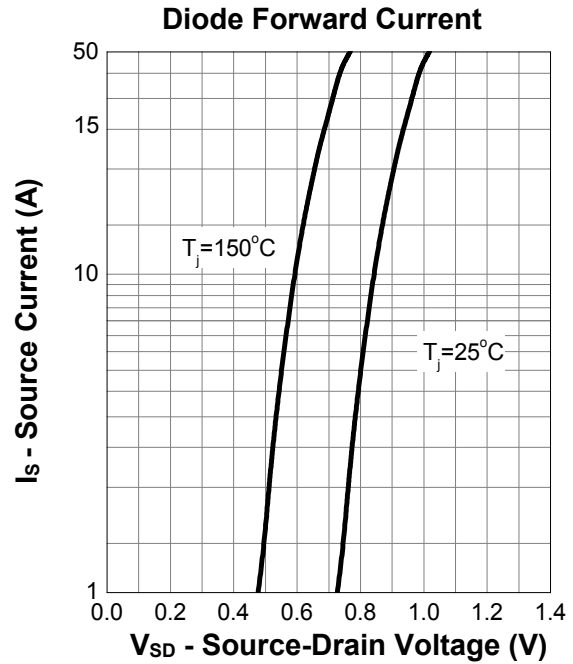
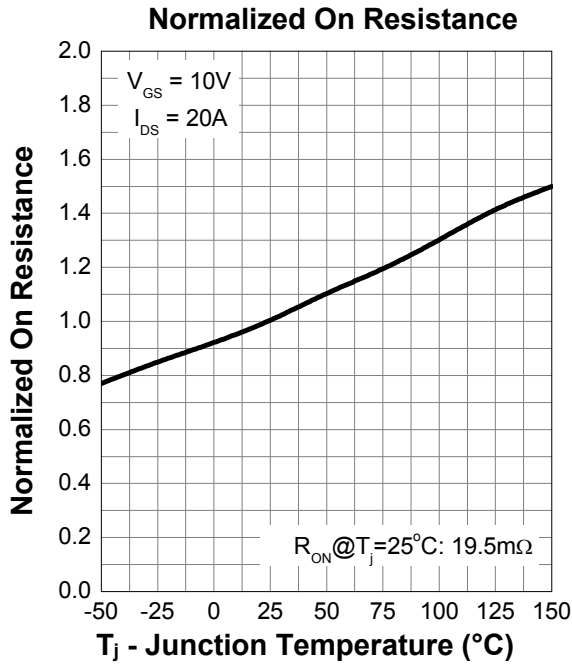

8.Package Dimensions

T0252-3L

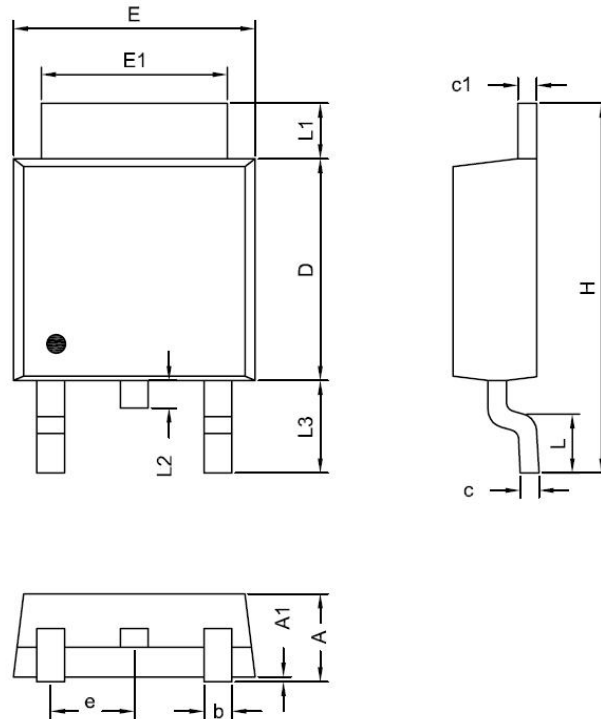

Symbol	Dimensions In Millimeters	
	MIN.	MAX.
A	2.19	2.38
A1	0.02	0.13
D	5.30	6.40
E	6.35	6.80
E1	5.20	5.50
c	0.40	0.60
c1	0.40	0.60
b	0.55	0.85
e	2.30 BCS	
L	1.00	1.80
L1	0.70	1.80
L2	0.70 BCS	
L3	2.40	2.80
H	9.20	10.40