

N-Channel Enhancement Mode MOSFET

1. Product Information

1.1 Features

- Surface-mounted package
- Super Trench
- Tj max 175°C
- Advanced trench cell design
- MSL1

1.2 Applications

- Motor drivers
- DC - DC Converter

1.3 Quick reference

- BV \geq 40 V
- P_{tot} \cong 35 W
- I_D \cong 136 A
- R_{DS(ON)} \leq 1.2 mΩ @ V_{GS} = 10 V
- R_{DS(ON)} \leq 3.6 mΩ @ V_{GS} = 6 V

2. Pin Description

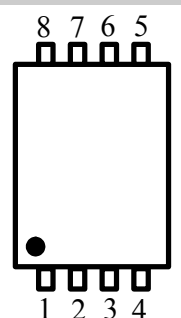
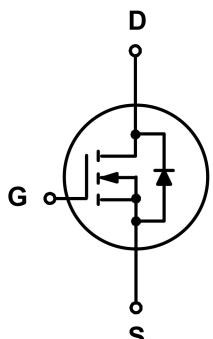
Pin	Description	Simplified Outline	Symbol
1,2,3	Source	 <p style="text-align: center;">Top View PDFN5x6-8L</p>	
4	Gate		
5,6,7,8	Drain		

3. Limiting Values

Symbol	Parameter	Conditions	Min	Max	Unit
V_{DS}	Drain-Source Voltage	$T_C = 25\text{ }^\circ\text{C}$	40	-	V
V_{GS}	Gate-Source Voltage	$T_C = 25\text{ }^\circ\text{C}$	-	± 20	V
I_D^*	Drain Current	$T_C = 25\text{ }^\circ\text{C}, V_{GS} = 10\text{ V}$	-	136	A
$I_{DM}^{*,**}$	Pulsed Source Current	$T_C = 25\text{ }^\circ\text{C}, V_{GS} = 10\text{ V}$	-	544	A
P_{tot}^*	Total Power Dissipation	$T_C = 25\text{ }^\circ\text{C}$	-	35	W
T_{stg}	Storage Temperature		-55	175	$^\circ\text{C}$
T_J	Junction Temperature		-	175	$^\circ\text{C}$
I_S	Diode Forward Current	$T_C = 25\text{ }^\circ\text{C}$	-	136	A
E_{AS}^*	Single Pulsed Avalanche Energy	$V_{DD} = 40\text{ V}, L = 1.0\text{ mH}$	-	722	mJ
$R_{\theta JA}^*$	Thermal Resistance- Junction to Ambient		-	62.5	$^\circ\text{C} / \text{W}$
$R_{\theta JC}^*$	Thermal Resistance- Junction to Case		-	3.5	

Notes :

* Surface Mounted on 1 in² pad area, $t \leq 10\text{ sec}$

** Pulse width $\leq 300\text{ }\mu\text{s}$, duty cycle $\leq 2\%$

*** Limited by bonding wire

4. Marking Information

Product Name	Marking
KJ007N04GHB	<div style="display: inline-block; border: 1px solid black; padding: 2px;">007N04HB</div> <div style="display: inline-block; border: 1px solid black; padding: 2px; margin-left: 5px;">YWWXXX</div> YWWXXX: Date Code

5. Ordering Code

Product Name	Package	Reel Size	Tape width	Quantity	Note
KJ007N04GHB	PDFN5*6			5000	

Note: KUAJIEXIN defines " Green " as lead-free (RoHS compliant) and halogen free (Br or Cl does not exceed 900 ppm by weight in homogeneous material and total of Br and Cl does not exceed 1500 ppm by weight; Follow IEC 61249-2-21 and IPC / JEDEC J-STD-020C)

6. Electrical Characteristics (T_A = 25 °C Unless Otherwise Noted)

Symbol	Parameter	Conditions	Min	Typ	Max	Unit
Static Characteristics						
B _V DSS	Drain-Source Breakdown Voltage	V _{GS} = 0 V, I _D = 250 μA	40	-	-	V
V _{GS(th)}	Gate Threshold Voltage	V _{DS} = V _{GS} , I _{DS} = 250 μA	2	-	4	V
I _{DSS}	Zero Gate Voltage Source Current	V _{DS} = 32 V, V _{GS} = 0 V	-	-	1	μA
		T _J = 85 °C	-	-	30	μA
I _{GSS}	Gate Leakage Current	V _{GS} = ± 20 V, V _{DS} = 0 V	-	-	± 100	nA
R _{DS(ON)} ^a	Drain-Source On-State Resistance	V _{GS} = 10 V, I _D = 30 A	-	1.05	1.2	mΩ
		V _{GS} = 6 V, I _D = 20 A	-	2.8	3.6	
Diode Characteristics						
V _{SD} ^a	Diode Forward Voltage	I _{SD} = 30 A, V _{GS} = 0 V	-	-	1.3	V
t _{rr}	Reverse Recovery Time	I _{SD} = 30 A, dI _{SD} /dt = 100 A/μs	-	62.3	-	nS
Q _{rr}	Reverse Recovery Charge		-	66.6	-	nC
Dynamic Characteristics^b						
C _{iss}	Input Capacitance	V _{GS} = 0 V, V _{DS} = 20 V Frequency = 1 MHz	-	4833	-	pF
C _{oss}	Output Capacitance		-	1958	-	
C _{rss}	Reverse Transfer Capacitance		-	181	-	
t _{d(on)}	Turn-on Delay Time	V _{DS} = 20 V, V _{GEN} = 10 V, R _G = 3.9 Ω, R _L = 0.66 Ω, I _{DS} = 30 A	-	19	-	nS
t _r	Turn-on Rise Time		-	79	-	
t _{d(off)}	Turn-off Delay Time		-	52	-	
t _f	Turn-off Fall Time		-	44	-	
Gate Charge Characteristics^b						
Q _g	Total Gate Charge	V _{DS} = 20 V, V _{GS} = 10 V, I _{DS} = 30 A	-	80	-	nC
Q _{gs}	Gate-Source Charge		-	27	-	
Q _{gd}	Gate-Drain Charge		-	19	-	

Notes :

- a : Pulse test ; pulse width ≤ 300 μs, duty cycle ≤ 2 %
- b : Guaranteed by design, not subject to production testing

7. Typical Characteristics (Cont.)

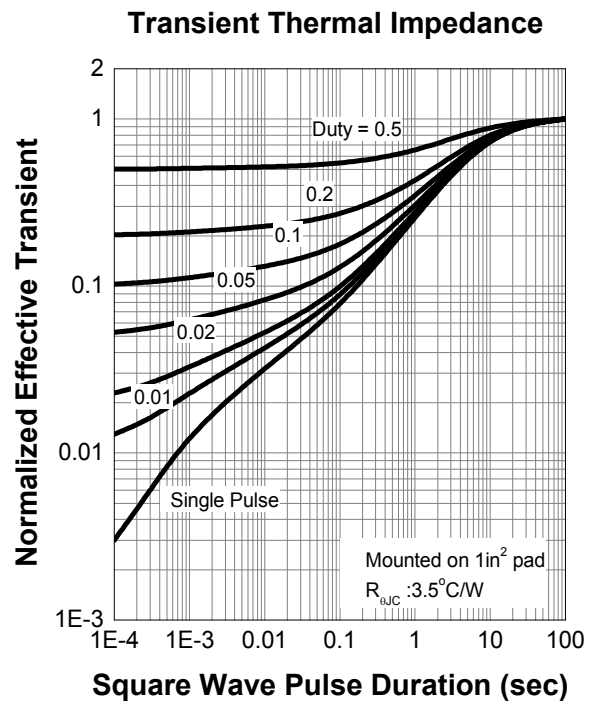
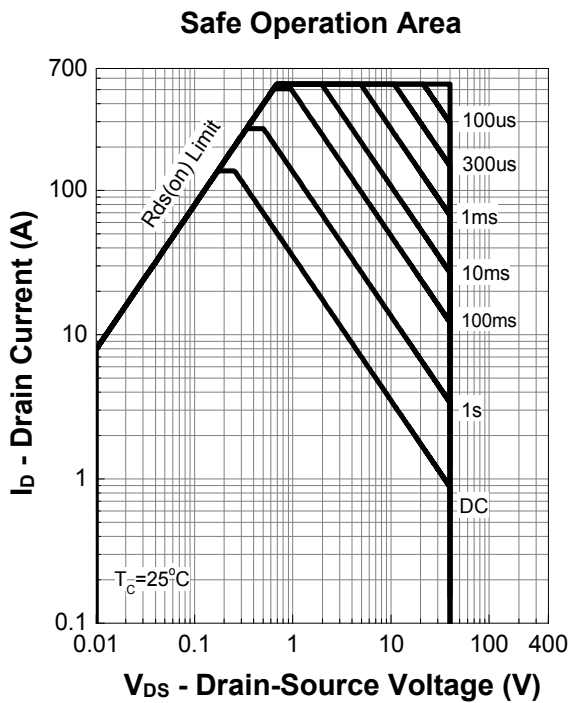
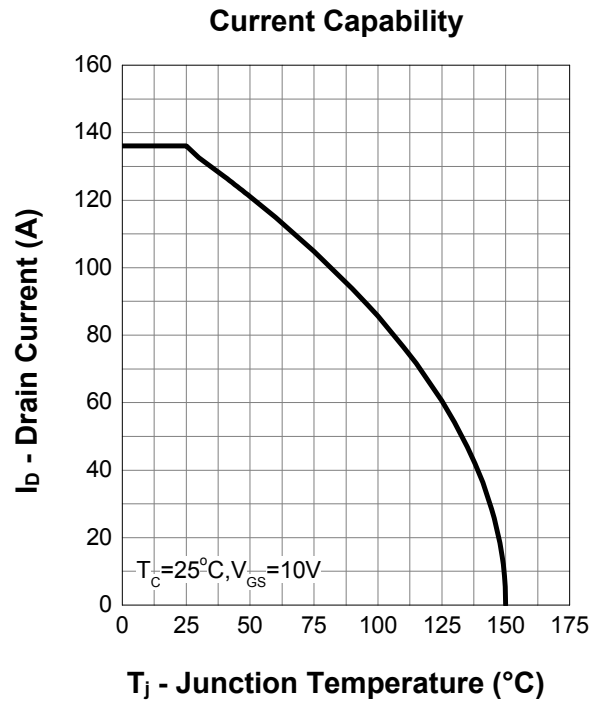
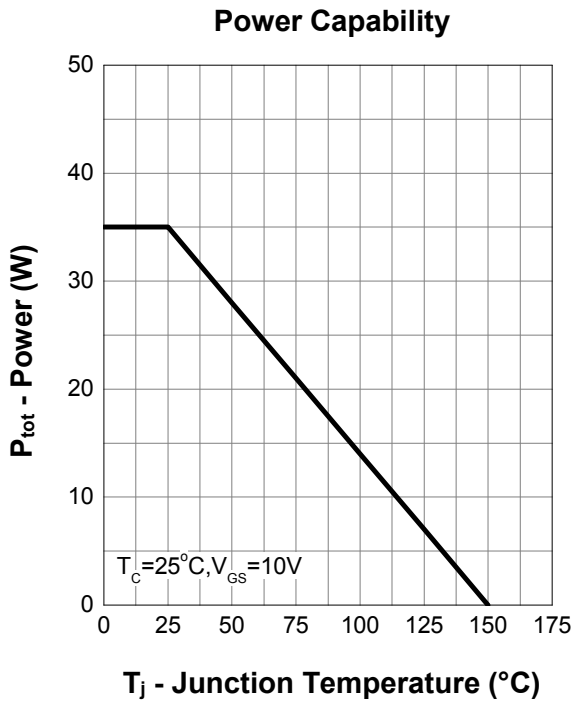

7. Typical Characteristics (Cont.)

Output Characteristics

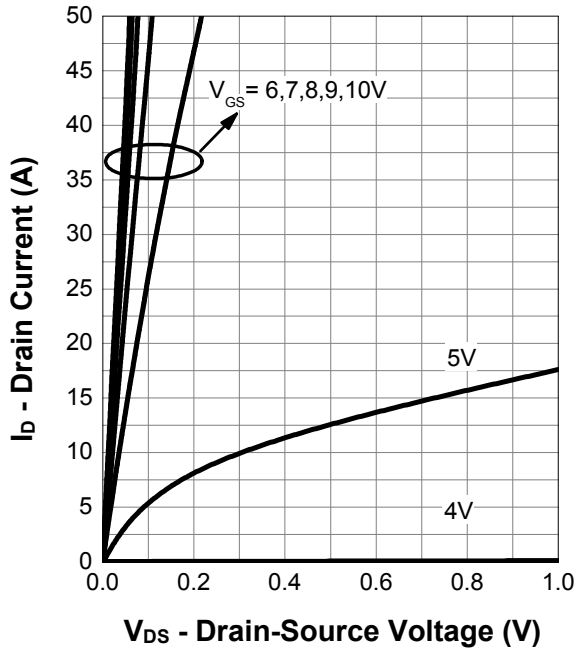

On Resistance

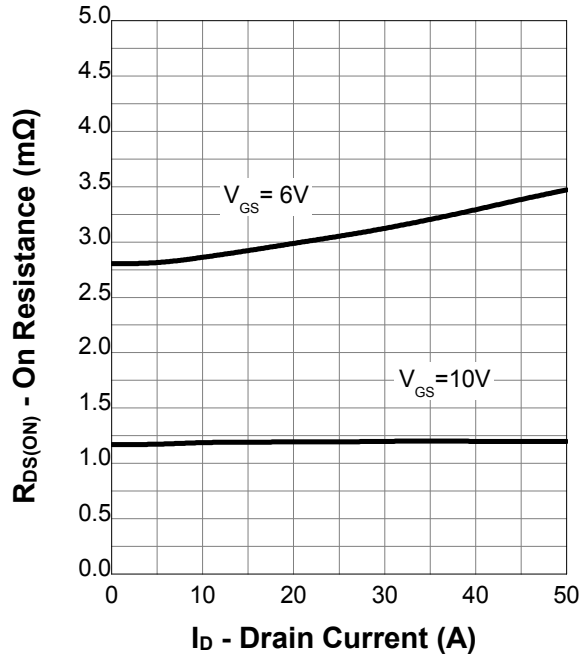

Transfer Characteristics

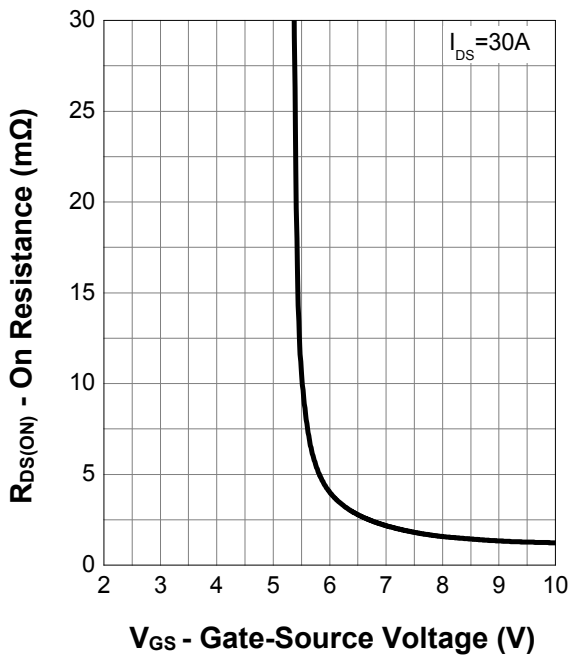

Normalized Threshold Voltage

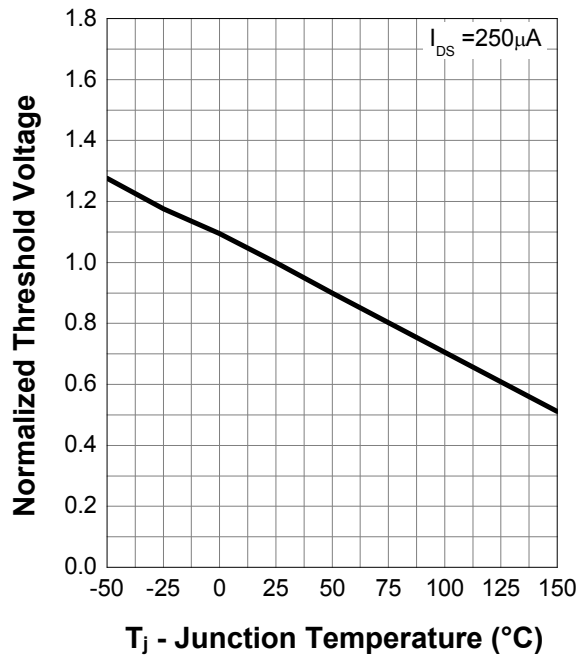

7. Typical Characteristics (Cont.)

Normalized On Resistance

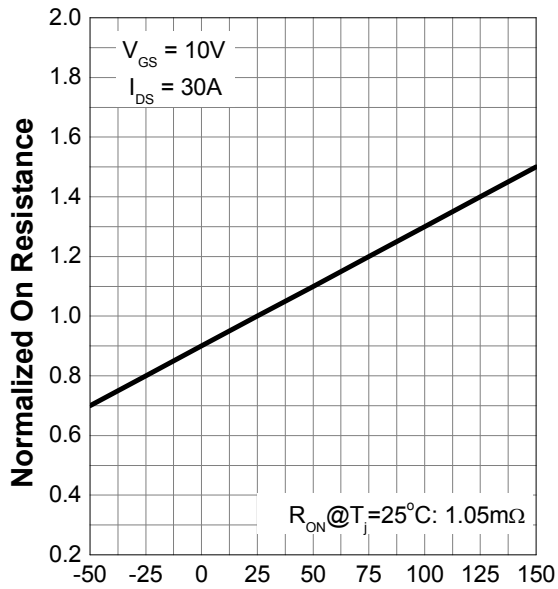

T_j - Junction Temperature ($^{\circ}\text{C}$)

Diode Forward Current

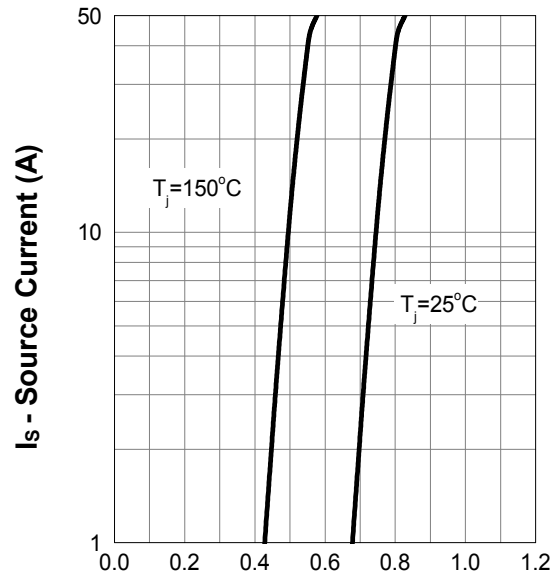

V_{SD} - Source-Drain Voltage (V)

Capacitance

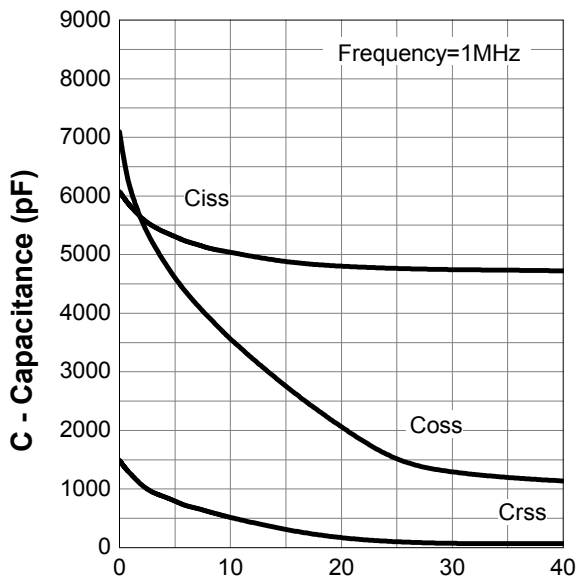

V_{DS} - Drain-Source Voltage (V)

Gate Charge

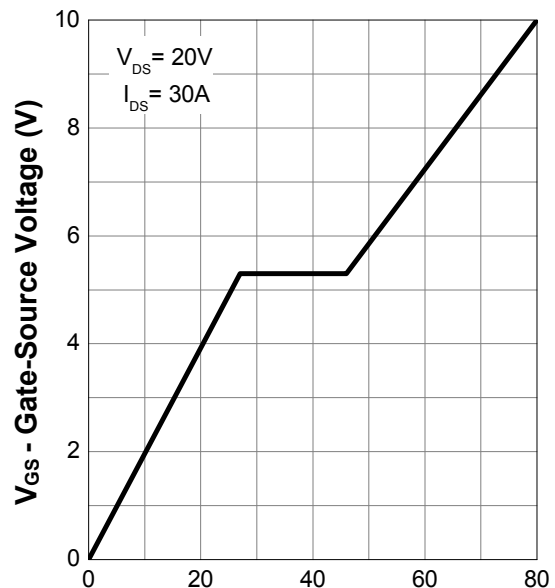

Q_G - Gate Charge (nC)

8. Package Dimensions

PDFN5x6 - 8L Package

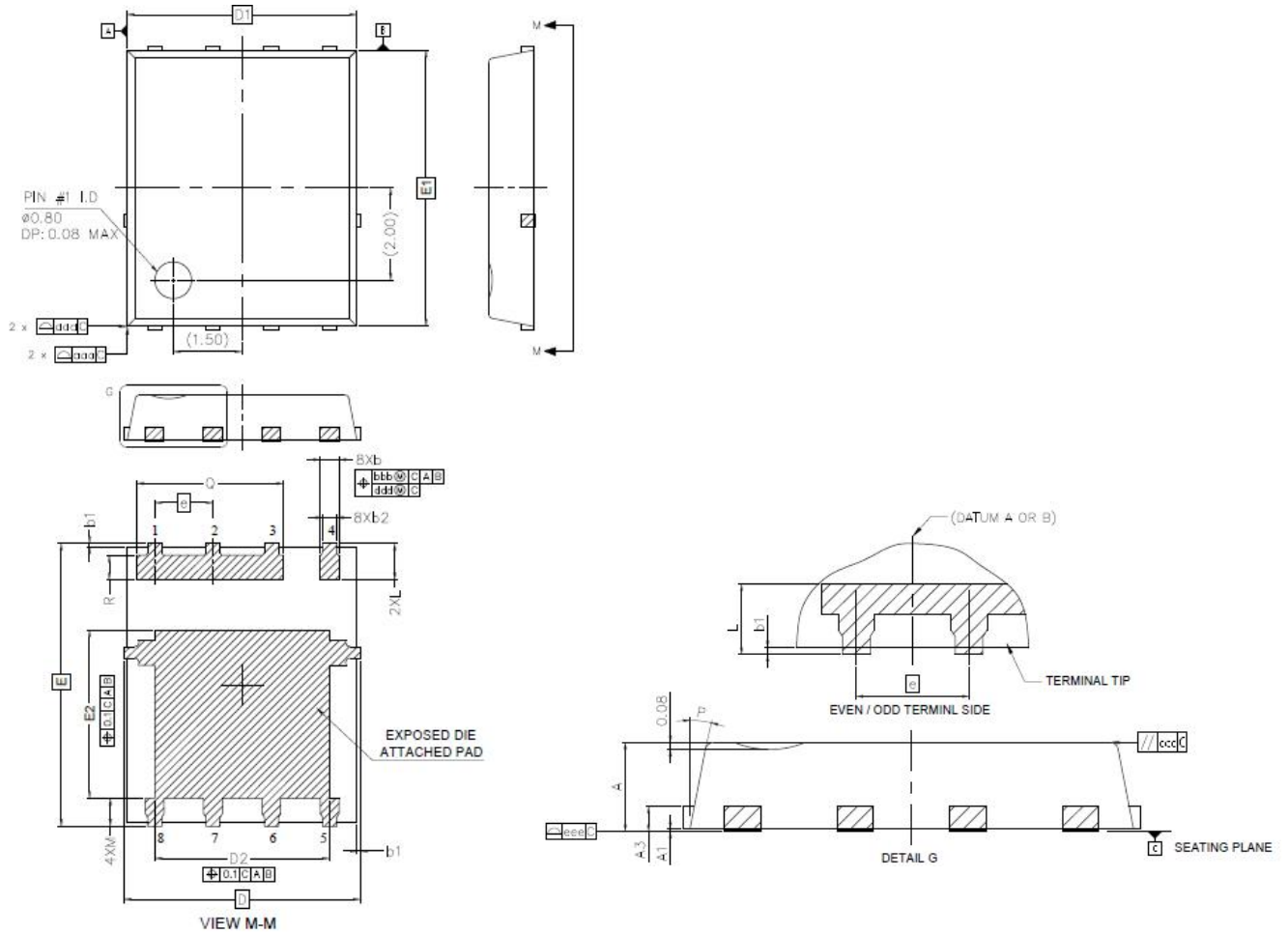

8. Package Dimensions

PDFN5x6 - 8L Package

Symbol	Dimensions In Millimeters	
	MIN.	MAX.
A	0.95	1.05
A1	0.00	0.05
A3	0.25 REF	
b	0.36	0.46
b1	0.03	0.13
b2	0.26	0.36
D	5.15 BSC	
D1	5.00 BSC	
D2	3.70	3.90
E	6.15 BSC	
E1	6.00 BSC	
E2	3.56	3.76
e	1.27 BSC	
L	0.74	0.84
M	0.55	0.66
P	10°	12°
Q	3.15	3.25
R	0.48	0.58
aaa	0.10	
bbb	0.10	
ccc	0.10	
ddd	0.05	
eee	0.08	