

Dual N-Channel Enhancement Mode MOSFET

1. Product Information

1.1 Features

- Surface-mounted package
- Advanced trench cell design

1.2 Applications

- MB and NB
- Motor drivers
- Half – bridge Drivers

1.3 Quick reference

- $BV \geq 40\text{ V}$
- $R_{DS(ON)} \leq 16\text{ m}\Omega @ V_{GS} = 10\text{ V}$
- $P_{tot} \leq 35\text{ W}$
- $R_{DS(ON)} \leq 22\text{ m}\Omega @ V_{GS} = 4.5\text{ V}$
- $I_D \leq 37\text{ A}$

2. Pin Description

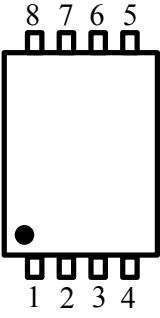
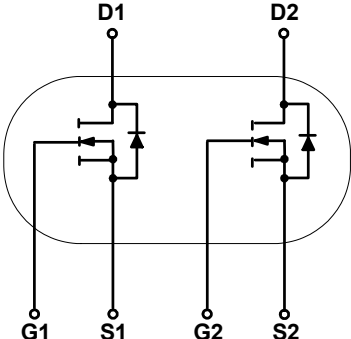
Pin	Description	Simplified Outline	Symbol
1	Source(S1)	 Top View PDFN5x6-8L	
2	Gate(G1)		
3	Source(S2)		
4	Gate(G2)		
5,6	Drain(D2)		
7,8	Drain(D1)		

3. Limiting Values

Symbol	Parameter	Conditions	Min	Max	Unit
V_{DS}	Drain-Source Voltage	$T_C = 25\text{ }^\circ\text{C}$	40	-	V
V_{GS}	Gate-Source Voltage	$T_C = 25\text{ }^\circ\text{C}$	-	± 20	V
I_D^*	Drain Current	$T_C = 25\text{ }^\circ\text{C}, V_{GS} = 10\text{ V}$	-	37	A
$I_{DM}^{*,**,***}$	Pulsed Drain Current	$T_C = 25\text{ }^\circ\text{C}, V_{GS} = 10\text{ V}$	-	80	A
P_{tot}	Total Power Dissipation	$T_C = 25\text{ }^\circ\text{C}$	-	35	W
T_{stg}	Storage Temperature		- 55	150	$^\circ\text{C}$
T_J	Junction Temperature		- 55	150	$^\circ\text{C}$
$R_{\theta JA}^*$	Thermal Resistance- Junction to Ambient		-	62.5	$^\circ\text{C} / \text{W}$
$R_{\theta JC}^*$	Thermal Resistance- Junction to Case		-	3.5	$^\circ\text{C} / \text{W}$

Notes :

- * Surface Mounted on 1 in² pad area, $t \leq 10\text{ sec}$
- ** Pulse width $\leq 10\text{ }\mu\text{s}$, duty cycle $\leq 1\%$
- *** Limited by bonding wire

4. Marking Information

Product Name	Marking
KJ4015G	<div style="display: inline-block; border: 1px solid black; padding: 2px;"> 4015 YWWXXX </div> YWWXXX: Date Code

5. Ordering Code

Product Name	Package	Reel Size	Tape width	Quantity	Note
KJ4015G	PDFN5*6			5000	

Note: KJ4015G defines " Green " as lead-free (RoHS compliant) and halogen free (Br or Cl does not exceed 900 ppm by weight in homogeneous material and total of Br and Cl does not exceed 1500 ppm by weight; Follow IEC 61249-2-21 and IPC / JEDEC J-STD-020C)

6. Electrical Characteristics ($T_A = 25\text{ }^\circ\text{C}$ Unless Otherwise Noted)

Symbol	Parameter	Conditions	Min	Typ	Max	Unit
Static Characteristics						
BV_{DSS}	Drain-Source Breakdown Voltage	$V_{GS} = 0\text{ V}, I_D = 250\text{ }\mu\text{A}$	40	-	-	V
$V_{GS(th)}$	Gate Threshold Voltage	$V_{DS} = V_{GS}, I_{DS} = 250\text{ }\mu\text{A}$	1	-	2	V
I_{DSS}	Zero Gate Voltage Source Current	$V_{DS} = 32\text{ V}, V_{GS} = 0\text{ V}$	-	-	1	μA
		$T_J = 85\text{ }^\circ\text{C}$	-	-	30	μA
I_{GSS}	Gate Leakage Current	$V_{GS} = \pm 20\text{ V}, V_{DS} = 0\text{ V}$	-	-	± 100	nA
$R_{DS(ON)}^a$	Drain-Source On-State Resistance	$V_{GS} = 10\text{ V}, I_D = 20\text{ A}$	-	13.5	16	m Ω
		$V_{GS} = 4.5\text{ V}, I_D = 10\text{ A}$	-	17.5	22	
Diode Characteristics						
V_{SD}^a	Diode Forward Voltage	$I_{SD} = 20\text{ A}, V_{GS} = 0\text{ V}$	-	-	1.3	V
t_{rr}	Reverse Recovery Time	$I_{SD} = 20\text{ A}, dI_{SD}/dt = 100\text{ A}/\mu\text{s}$	-	11	-	nS
Q_{rr}	Reverse Recovery Charge		-	5.5	-	nC
Dynamic Characteristics						
C_{iss}	Input Capacitance	$V_{GS} = 0\text{ V}, V_{DS} = 20\text{ V}$ Frequency = 1 MHz	-	1012	-	pF
C_{oss}	Output Capacitance		-	78	-	
C_{rss}	Reverse Transfer Capacitance		-	72	-	
$t_d(on)$	Turn-on Delay Time	$V_{DS} = 20\text{ V}, V_{GEN} = 10\text{ V},$ $R_G = 4.5\text{ }\Omega, R_L = 1\text{ }\Omega,$ $I_D = 20\text{ A}$	-	7	-	nS
t_r	Turn-on Rise Time		-	45	-	
$t_d(off)$	Turn-off Delay Time		-	17	-	
t_f	Turn-off Fall Time		-	23	-	
Gate Charge Characteristics^b						
Q_g	Total Gate Charge	$V_{GS} = 10\text{ V}, V_{DS} = 20\text{ V},$ $I_{DS} = 20\text{ A}$	-	20	-	nC
Q_{gs}	Gate-Source Charge		-	4.1	-	
Q_{gd}	Gate-Drain Charge		-	3.4	-	

Notes :

 a : Pulse test ; pulse width $\leq 300\text{ }\mu\text{s}$, duty cycle $\leq 2\%$

b : Guaranteed by design, not subject to production testing

7. Typical Characteristics

Power Capability

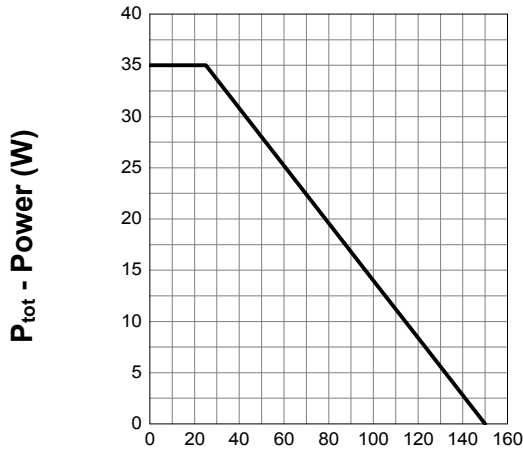

T_{mp} - Mounting Point Temp. (°C)

Current Capability

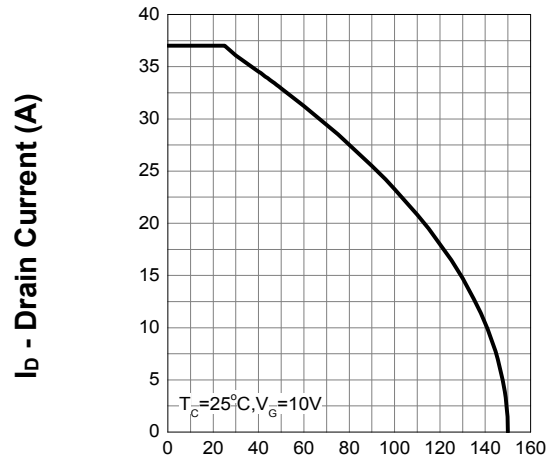

T_{mp} - Mounting Point Temp. (°C)

Safe Operation Area

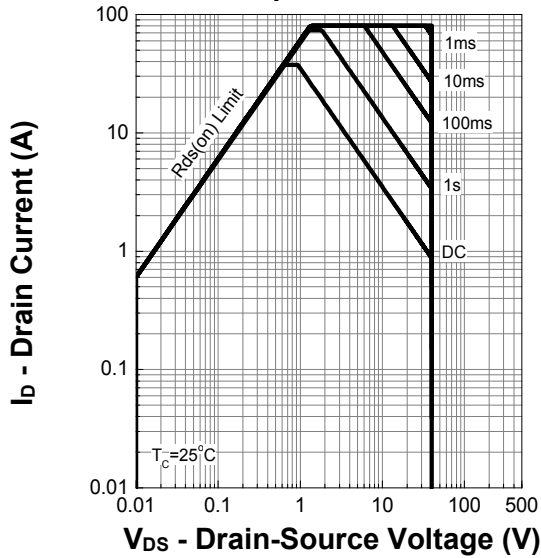

Transient Thermal Impedance

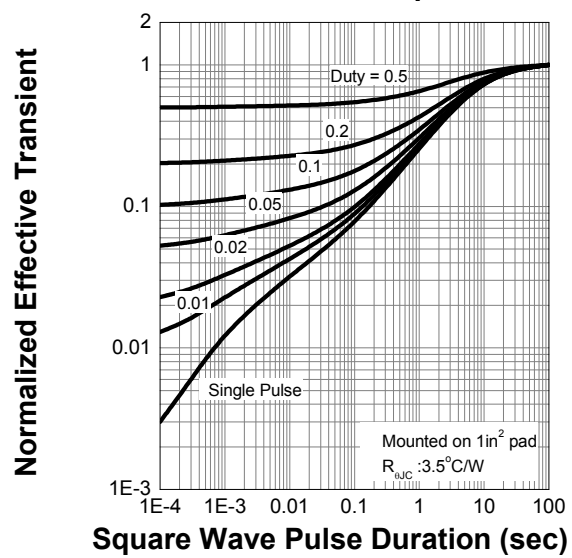

7. Typical Characteristics (cont.)

Output Characteristics

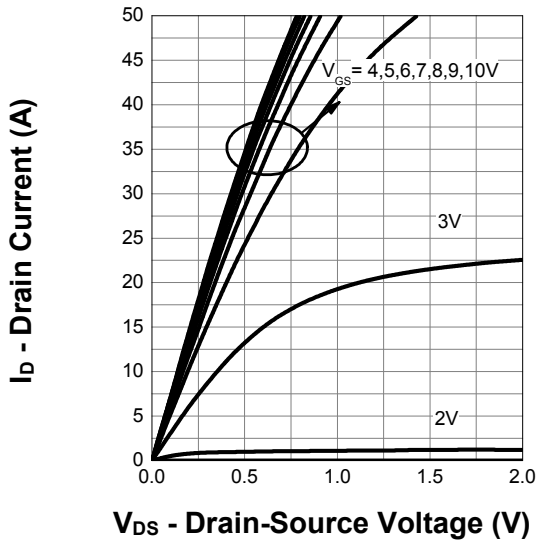

On Resistance

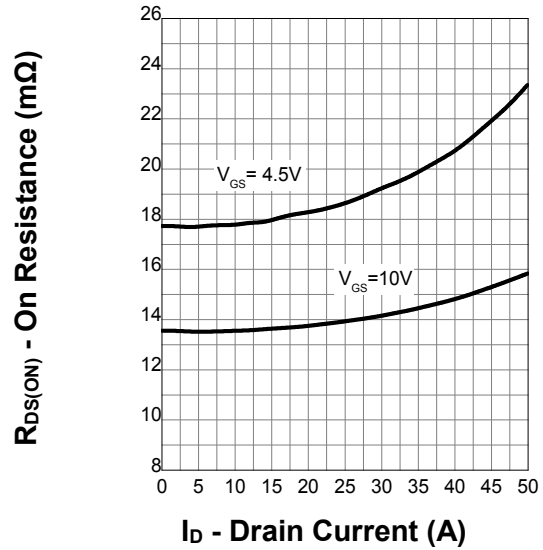

Transfer Characteristics

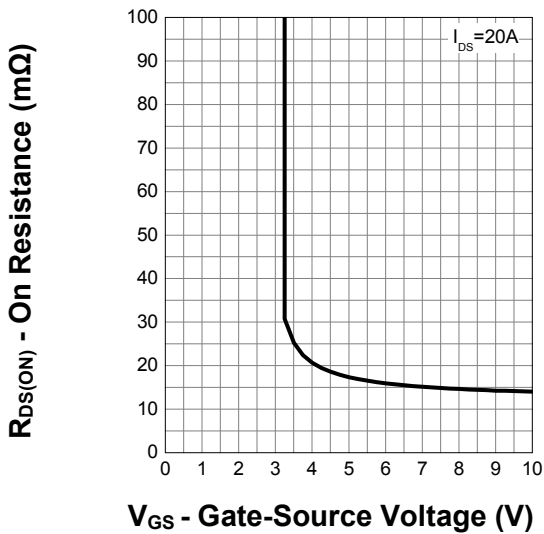

Normalized Threshold Voltage

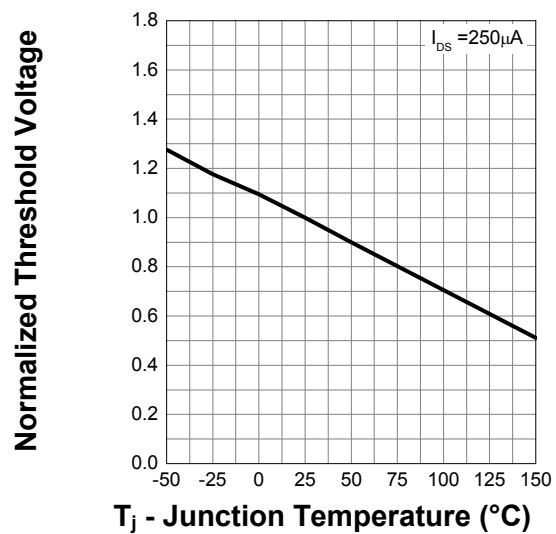

7. Typical Characteristics (cont.)

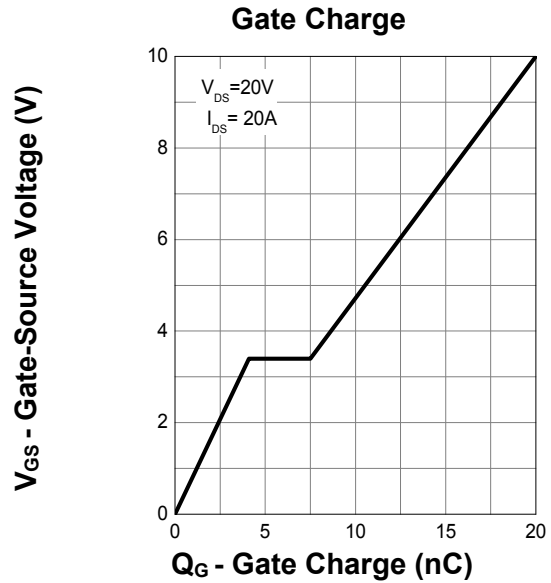
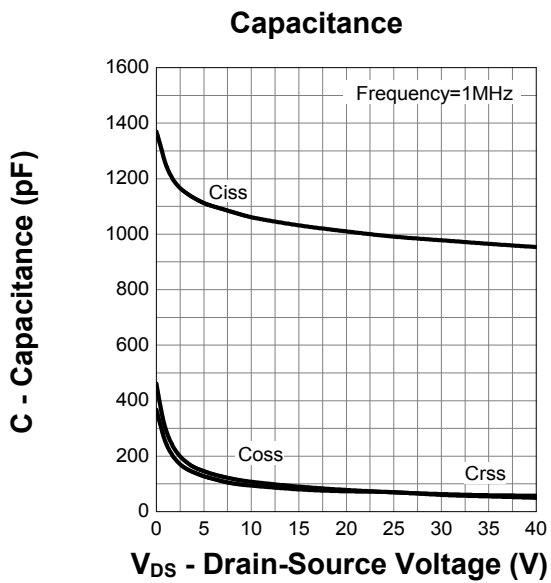
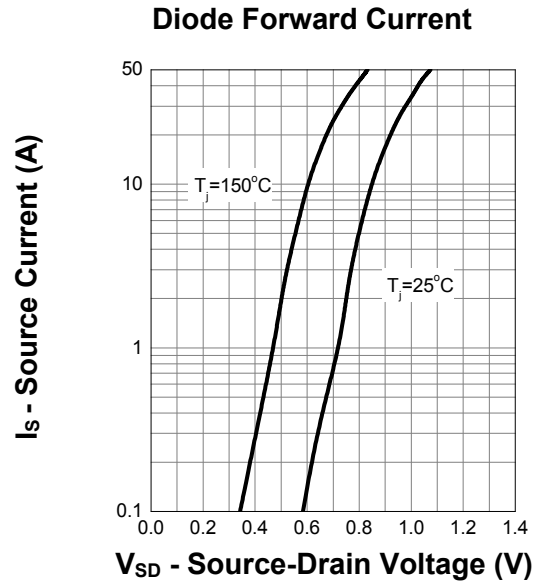
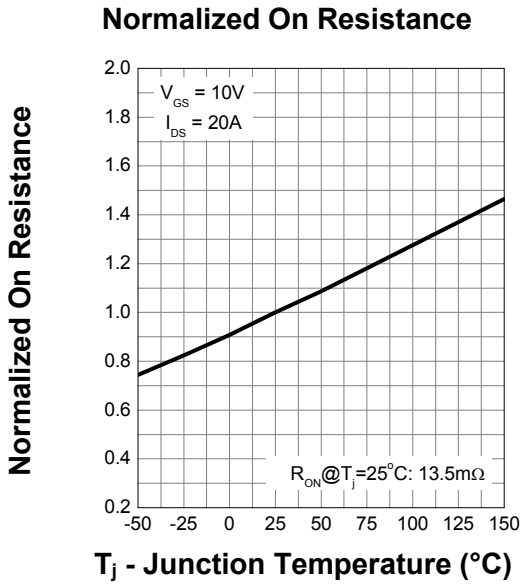

8. Package Dimensions

PDFN5x6 - 8L (Dual) Package

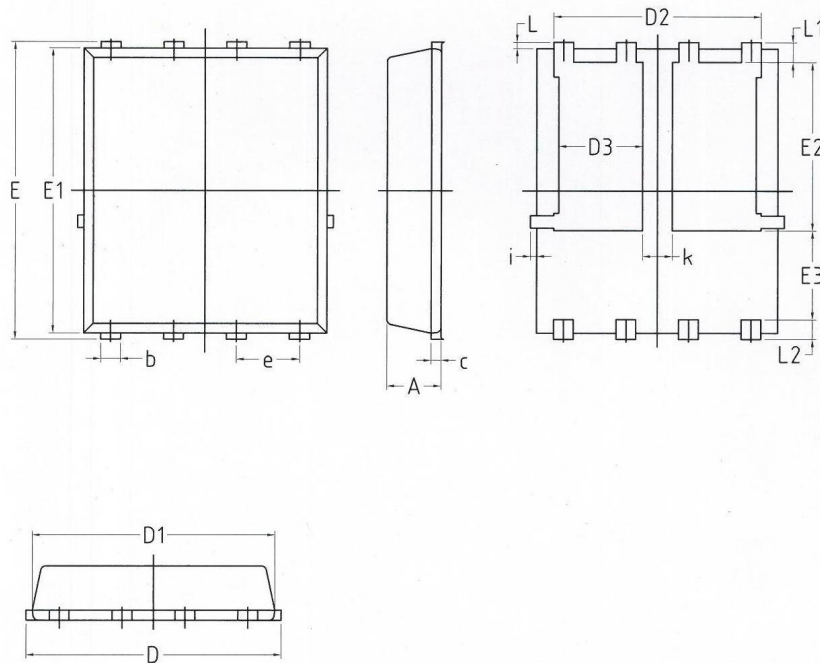

Symbol	Dimensions In Millimeters	
	MIN.	MAX.
A	1.03	1.17
B	0.34	0.48
c	0.203 BSC	
D	4.8	5.4
D1	4.8	5.0
D2	4.11	4.31
D3	1.6	1.8
E	5.95	6.15
E1	5.65	5.85
E2	3.3	3.5
E3	1.7	-
e	1.27 BSC	
L	0.05	0.25
L1	0.38	0.5
L2	0.38	0.5
i	-	0.18
k	0.5	0.7