

N-Channel Enhancement Mode MOSFET

1. Product Information

1.1 Features

- Surface-mounted package
- Advanced trench cell design

1.2 Applications

- Motor appliances
- High power inverter system

1.3 Quick reference

- $BV \geq 30\text{ V}$
- $R_{DS(ON)} \leq 6.5\text{ m}\Omega @ V_{GS} = 10\text{ V}$
- $P_{tot} \leq 35\text{ W}$
- $R_{DS(ON)} \leq 10.5\text{ m}\Omega @ V_{GS} = 4.5\text{ V}$
- $I_D \leq 50\text{ A}$

2. Pin Description

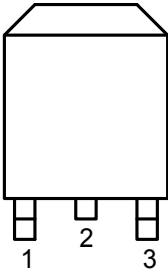
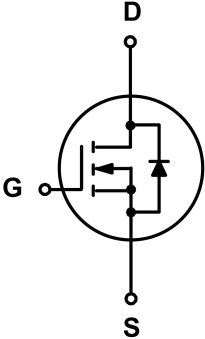
Pin	Description	Simplified Outline	Symbol
1	Gate(G)	 <p>Top View TO-252</p>	
2	Drain(D)		
3	Source(S)		

3. Limiting Values

Symbol	Parameter	Conditions	Min	Max	Unit
V_{DS}	Drain-Source Voltage	$T_A = 25\text{ }^\circ\text{C}$	-	30	V
V_{GS}	Gate-Source Voltage	$T_A = 25\text{ }^\circ\text{C}$	-	± 20	V
I_D^*	Drain Current	$T_A = 25\text{ }^\circ\text{C}, V_{GS} = 10\text{ V}$	-	50	A
		$T_A = 100\text{ }^\circ\text{C}, V_{GS} = 10\text{ V}$	-	30	A
$I_{DM}^{*,**}$	Pulsed Drain Current	$T_A = 25\text{ }^\circ\text{C}, V_{GS} = 10\text{ V}$	-	50	A
P_{tot}	Total Power Dissipation	$T_A = 25\text{ }^\circ\text{C}$	-	35	W
T_{stg}	Storage Temperature		- 55	150	$^\circ\text{C}$
T_J	Junction Temperature		- 55	150	$^\circ\text{C}$
I_S	Diode Forward Current	$T_A = 25\text{ }^\circ\text{C}$	-	50	A
$R_{\theta JA}^*$	Thermal Resistance- Junction to Ambient		-	62.5	$^\circ\text{C} / \text{W}$

Notes :

* Surface Mounted on 1 in² pad area, $t \leq 10\text{ sec}$

** Pulse width $\leq 300\text{ }\mu\text{s}$, duty cycle $\leq 2\%$

4. Marking Information

Product Name	Marking		
KJ50N03KA	<table border="1"> <tr> <td>50N03 YWWXXX</td> <td>YXXWWW : Date Code</td> </tr> </table>	50N03 YWWXXX	YXXWWW : Date Code
50N03 YWWXXX	YXXWWW : Date Code		

5. Ordering Code

Product Name	Package	Reel Size	Tape width	Quantity	Note
KJ50N03KA	TO-252			2500	

Note: KUAJIEXIN defines "Green" as lead-free (RoHS compliant) and halogen free (Br or Cl does not exceed 900 ppm by weight in homogeneous material and total of Br and Cl does not exceed 1500 ppm by weight; Follow IEC 61249-2-21 and IPC / JEDEC J-STD-020C)

6. Electrical Characteristics ($T_A=25\text{ }^\circ\text{C}$ Unless Otherwise Noted)

Symbol	Parameter	Conditions	Min	Typ	Max	Unit
Static Characteristics						
BV_{DSS}	Drain-Source Breakdown Voltage	$V_{GS} = 0\text{ V}, I_{DS} = 250\text{ }\mu\text{A}$	30	-	-	V
$V_{GS(th)}$	Gate Threshold Voltage	$V_{DS} = V_{GS}, I_{DS} = 250\text{ }\mu\text{A}$	1.0	-	2.0	V
I_{DSS}	Drain Leakage Current	$V_{DS} = 24\text{ V}, V_{GS} = 0\text{ V}$	-	-	1	μA
		$T_J = 85\text{ }^\circ\text{C}$	-	-	30	μA
I_{GSS}	Gate Leakage Current	$V_{GS} = \pm 20\text{ V}, V_{DS} = 0\text{ V}$	-	-	± 100	nA
$R_{DS(ON)}^a$	On-State Resistance	$V_{GS} = 10\text{ V}, I_{DS} = 10\text{ A}$	-	5.7	6.5	m Ω
		$V_{GS} = 4.5\text{ V}, I_{DS} = 5\text{ A}$	-	8.5	10.5	
Diode Characteristics						
V_{SD}^a	Diode Forward Voltage	$I_{SD} = 10\text{ A}, V_{GS} = 0\text{ V}$	-	-	1.3	V
t_{rr}	Reverse Recovery Time	$I_{DS} = 10\text{ A}, V_{GS} = 0\text{ V}$ $di_{SD}/dt = 100\text{ A}/\mu\text{s}$	-	34	-	ns
Q_{rr}	Reverse Recovery Charge		-	7.1	-	μC
Dynamic Characteristics^b						
C_{iss}	Input Capacitance	$V_{GS} = 0\text{ V}, V_{DS} = 15\text{ V}$ Frequency = 1 MHz	-	1145	-	pF
C_{oss}	Output Capacitance		-	106	-	
C_{rss}	Reverse Transfer Capacitance		-	87	-	
$t_{d(on)}$	Turn-on Delay Time	$V_{DS} = 15\text{ V}, V_{GEN} = 10\text{ V},$ $R_G = 4.5\text{ }\Omega, R_L = 1.5\text{ }\Omega,$ $I_{DS} = 10\text{ A}$	-	7	-	ns
t_r	Turn-on Rise Time		-	30	-	
$t_{d(off)}$	Turn-off Delay Time		-	19	-	
t_f	Turn-off Fall Time		-	18	-	
Gate Charge Characteristics^b						
Q_g	Total Gate Charge	$V_{GS} = 15\text{ V}, V_{DS} = 10\text{ V},$ $I_{DS} = 10\text{ A}$	-	22	-	nC
Q_{gs}	Gate-Source Charge		-	5	-	
Q_{gd}	Gate-Drain Charge		-	3.3	-	

Notes :

a : Pulse test ; pulse width $\leq 300\text{ }\mu\text{s}$, duty cycle $\leq 2\%$

b : Guaranteed by design, not subject to production testing

7. Typical Characteristics

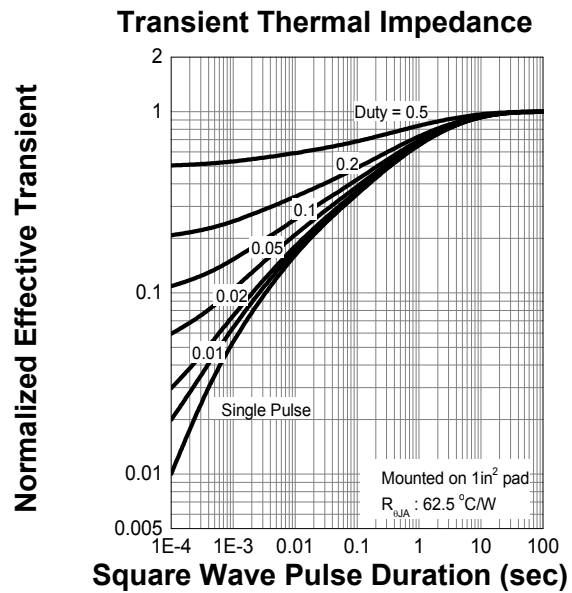
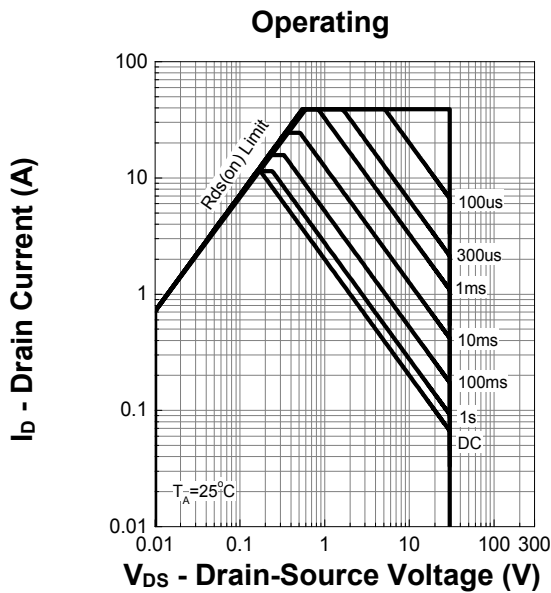
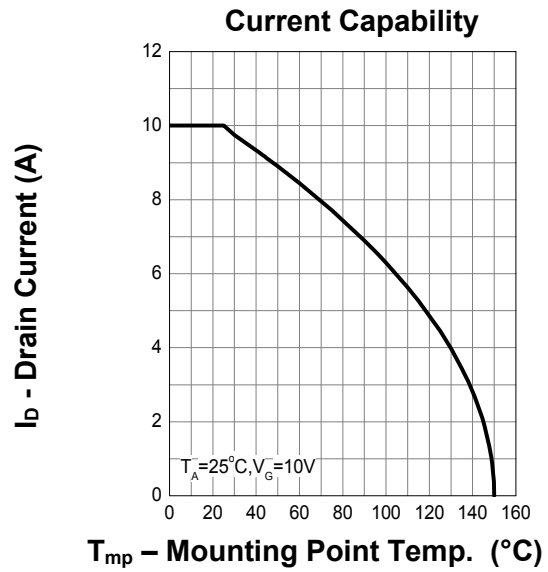
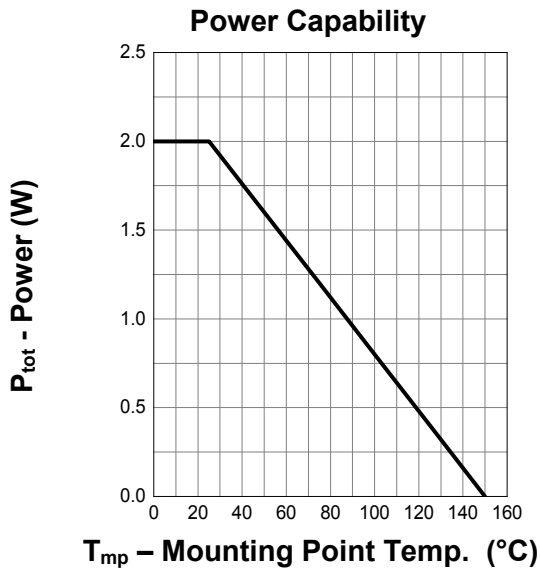

7. Typical Characteristics (cont.)

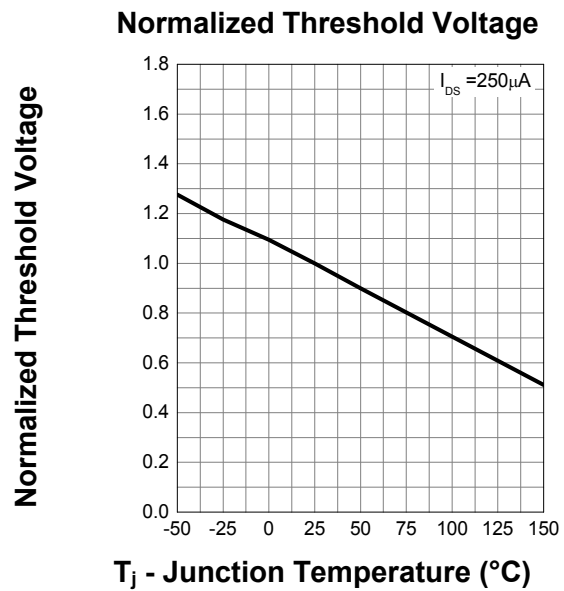
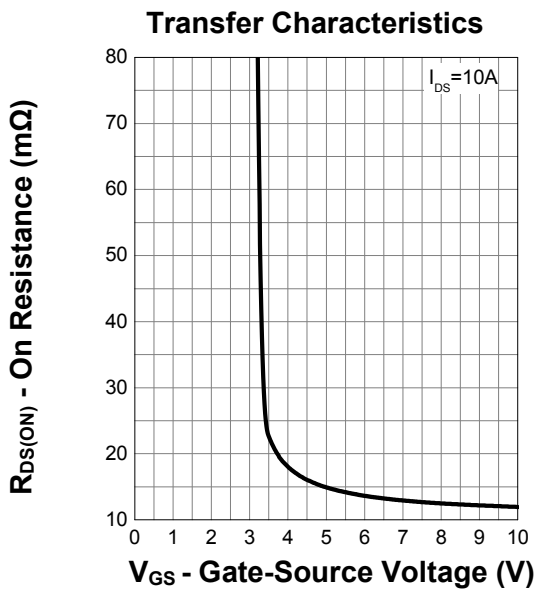
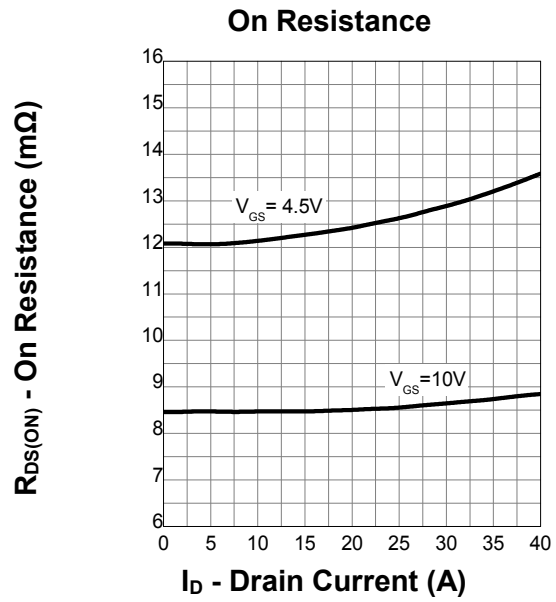
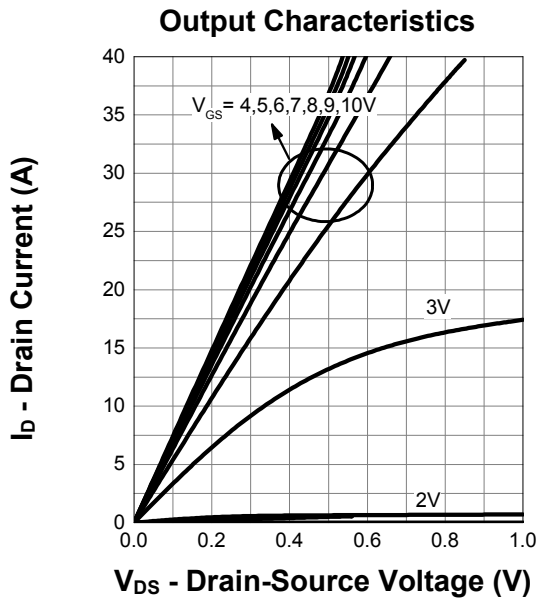

7. Typical Characteristics (cont.)

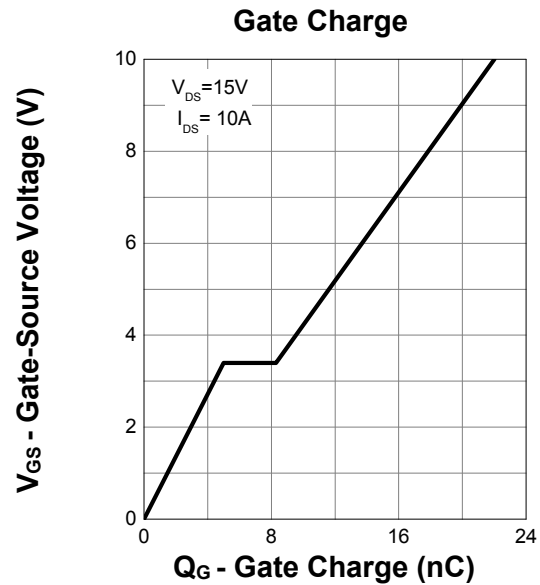
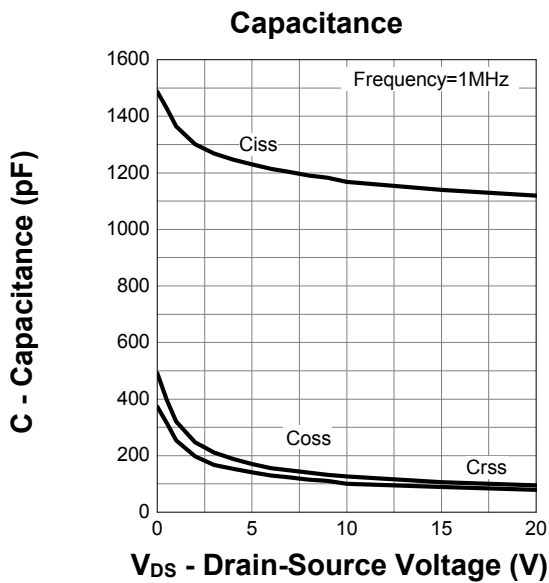
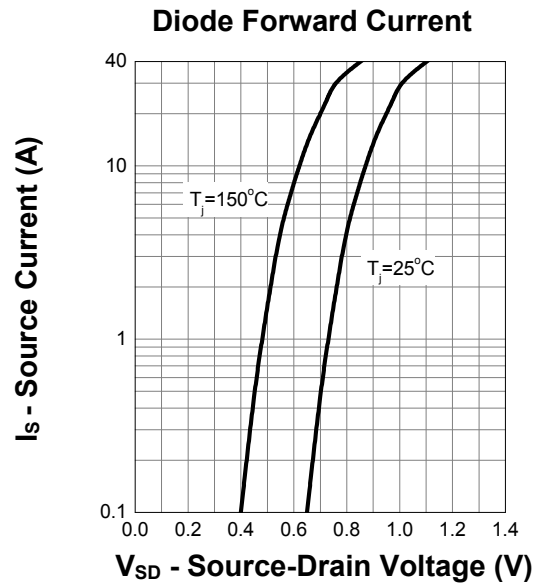
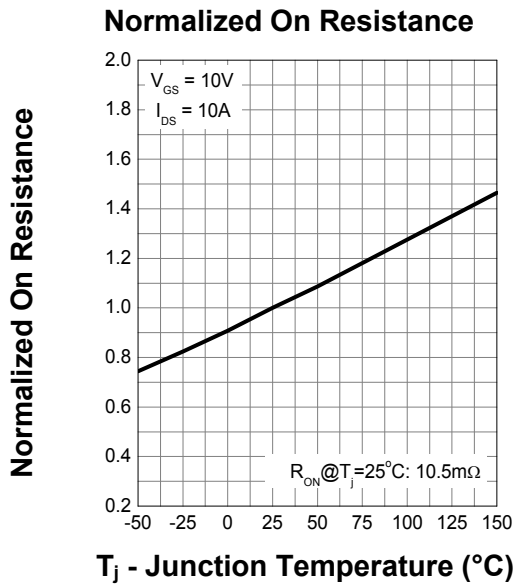

8.Package Dimensions

TO252-3L

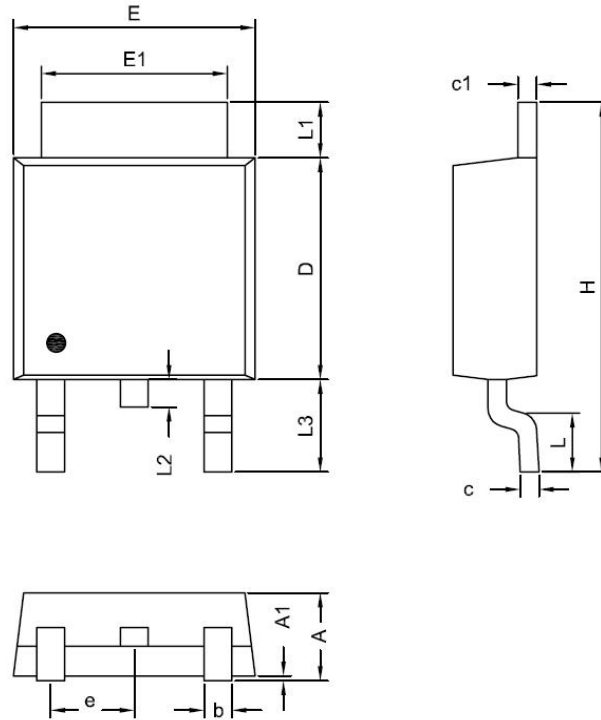

Symbol	Dimensions In Millimeters	
	MIN.	MAX.
A	2.19	2.38
A1	0.02	0.13
D	5.30	6.40
E	6.35	6.80
E1	5.20	5.50
c	0.40	0.60
c1	0.40	0.60
b	0.55	0.85
e	2.30 BCS	
L	1.00	1.80
L1	0.70	1.80
L2	0.70 BCS	
L3	2.40	2.80
H	9.20	10.40