

N-Channel Enhancement Mode MOSFET

1. Product Information

1.1 Features

- Surface-mounted package
 Advanced trench cell design
- Extremely low threshold voltage
 ESD protected

1.2 Applications

- Portable appliances
 High speed switch
- Battery management
 Low power DC to DC Converter

1.3 Quick reference

- $BV \leq 20\text{ V}$
 $P_{\text{tot}} \leq 0.27\text{ W}$
 $I_D \leq 0.57\text{ A}$
- $R_{\text{DS(ON)}} \leq 0.55\ \Omega @ V_{\text{GS}} = 4.5\text{ V}$
 $R_{\text{DS(ON)}} \leq 0.7\ \Omega @ V_{\text{GS}} = 2.5\text{ V}$
 $R_{\text{DS(ON)}} \leq 0.9\ \Omega @ V_{\text{GS}} = 1.8\text{ V}$

2. Pin Description

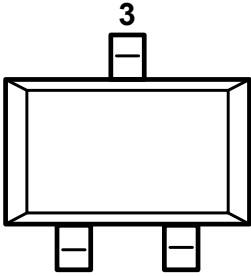
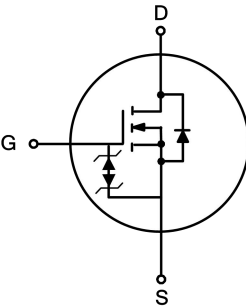
Pin	Description	Simplified Outline	Symbol
1	Gate(G)	 Top View SOT523-3L	
2	Source(S)		
3	Drain(D)		

3. Limiting Values

Symbol	Parameter	Conditions	Min	Max	Unit
V_{DS}	Drain-Source Voltage	$T_A = 25\text{ }^\circ\text{C}$	-	20	V
V_{GS}	Gate-Source Voltage	$T_A = 25\text{ }^\circ\text{C}$	-	± 10	V
I_D^*	Drain Current	$T_A = 25\text{ }^\circ\text{C}, V_{GS} = 4.5\text{ V}$	-	0.57	A
$I_{DM}^{*,**}$	Pulsed Drain Current	$T_A = 25\text{ }^\circ\text{C}, V_{GS} = 4.5\text{ V}$	-	2.2	A
P_{tot}	Total Power Dissipation	$T_A = 25\text{ }^\circ\text{C}$	-	0.27	W
T_{stg}	Storage Temperature		- 55	150	$^\circ\text{C}$
T_J	Junction Temperature		-	150	$^\circ\text{C}$
I_S	Diode Forward Current	$T_A = 25\text{ }^\circ\text{C}$	-	0.57	A
$R_{\theta JA}$	Thermal Resistance- Junction to Ambient		-	461	$^\circ\text{C} / \text{W}$

Notes :

- * Surface Mounted on 1 in² pad area, $t \leq 10\text{ sec}$
- ** Pulse width $\leq 300\text{ }\mu\text{s}$, duty cycle $\leq 2\%$

4. Marking Information

Product Name	Marking
KJ1R600S	<div style="display: inline-block; border: 1px solid black; padding: 2px;">NA YWW</div> YWW: Date Code

5. Ordering Code

Product Name	Package	Reel Size	Tape width	Quantity	Note
KJ1R600S	SOT523				

Note: KUAJIEXIN defines "Green" as lead-free (RoHS compliant) and halogen free (Br or Cl does not exceed 900 ppm by weight in homogeneous material and total of Br and Cl does not exceed 1500 ppm by weight; Follow IEC 61249-2-21 and IPC / JEDEC J-STD-020C)

6. Electrical Characteristics (T_A = 25 °C Unless Otherwise Noted)

Symbol	Parameter	Conditions	Min	Typ	Max	Unit
Static Characteristics						
BV _{DSS}	Drain-Source Breakdown Voltage	V _{GS} = 0 V, I _{DS} = 250 μA	20	-	-	V
V _{GS(th)}	Gate Threshold Voltage	V _{DS} = V _{GS} , I _{DS} = 250 μA	0.5	-	1	V
I _{DSS}	Drain Leakage Current	V _{DS} = 16 V, V _{GS} = 0V	-	-	1	μA
		T _J = 85 °C	-	-	30	μA
I _{GSS}	Gate Leakage Current	V _{GS} = ± 10 V, V _{DS} = 0 V	-	-	± 10	uA
R _{DS(ON)} ^a	On-State Resistance	V _{GS} = 4.5 V, I _{DS} = 0.5 A	-	0.43	0.55	Ω
		V _{GS} = 2.5 V, I _{DS} = 0.2 A	-	0.55	0.7	
		V _{GS} = 1.8 V, I _{DS} = 0.1 A	-	0.7	0.9	
Diode Characteristics						
V _{SD} ^a	Diode Forward Voltage	I _{SD} = 0.5 A, V _{GS} = 0V	-	-	1.2	V
Dynamic Characteristics^b						
C _{iss}	Input Capacitance	V _{GS} = 0 V, V _{DS} = 10 V Frequency = 1 MHz	-	34	-	pF
C _{oss}	Output Capacitance		-	2.8	-	
C _{rss}	Reverse Transfer Capacitance		-	0.9	-	
t _{d(on)}	Turn-on Delay Time	V _{DS} = 10 V, V _{GEN} = 4.5 V, R _G = 4.5 Ω, R _L = 20 Ω, I _{DS} = 0.5 A	-	1.4	-	ns
t _r	Turn-on Rise Time		-	18	-	
t _{d(off)}	Turn-off Delay Time		-	30	-	
t _f	Turn-off Fall Time		-	20	-	
Gate Charge Characteristics^b						
Q _g	Total Gate Charge	V _{DS} = 10 V, V _{GS} = 4.5 V, I _{DS} = 0.5 A	-	0.82	-	nC
Q _{gs}	Gate-Source Charge		-	0.18	-	
Q _{gd}	Gate-Drain Charge		-	0.11	-	

Notes :

a : Pulse test ; pulse width ≤ 300 μs, duty cycle ≤ 2 %

b : Guaranteed by design, not subject to production testing

7. Typical Characteristics

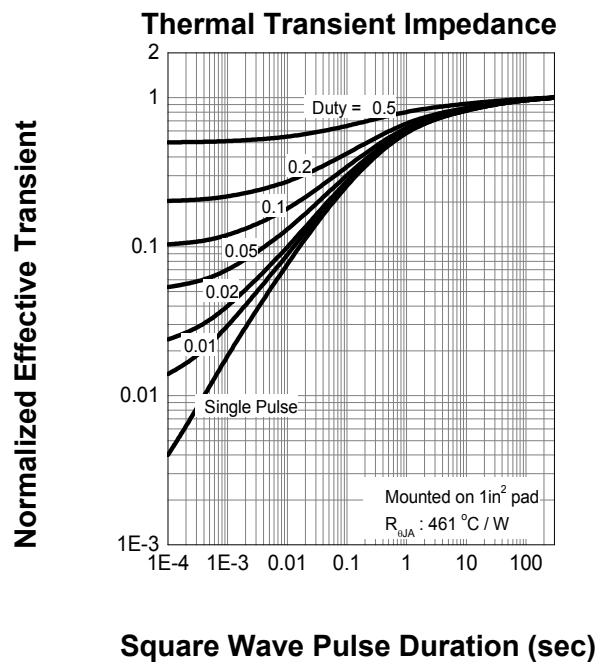
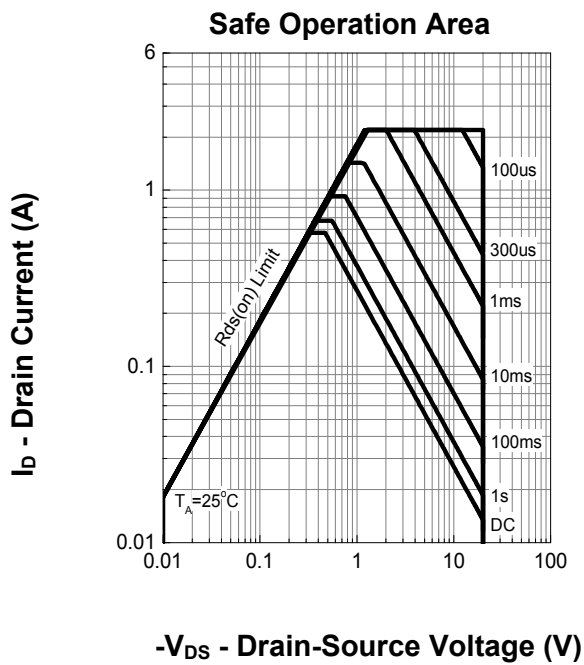
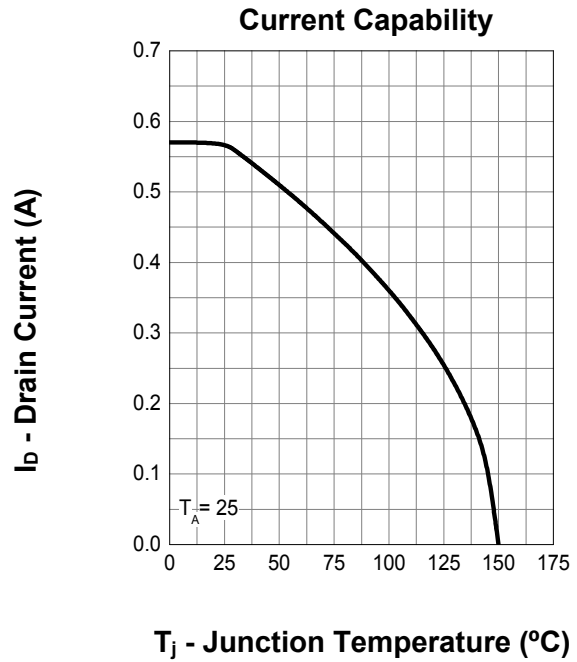
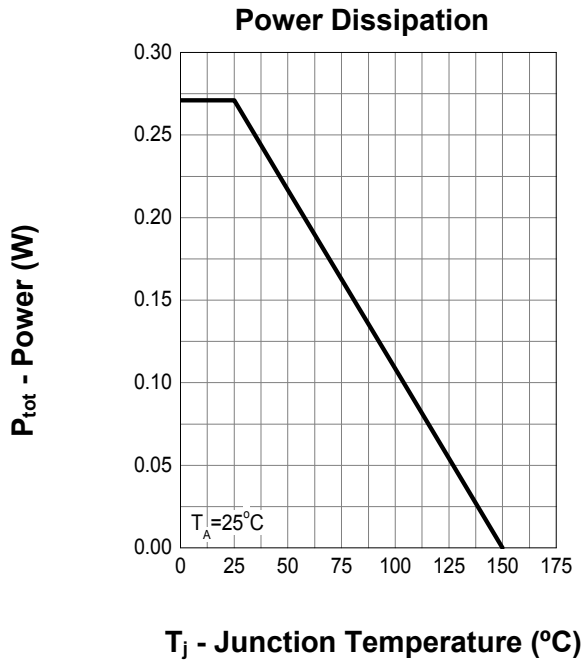

7. Typical Characteristics (cont.)

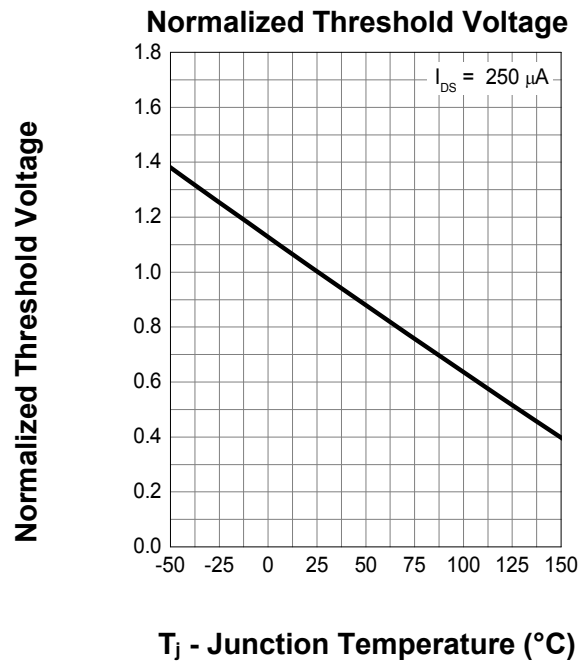
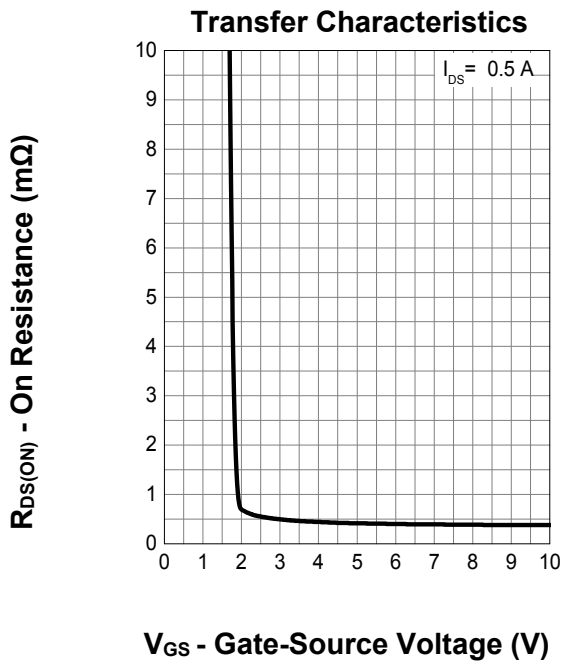
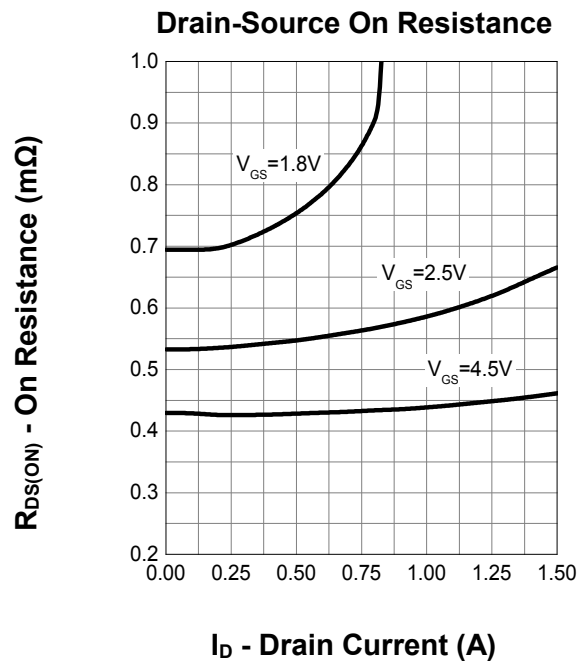
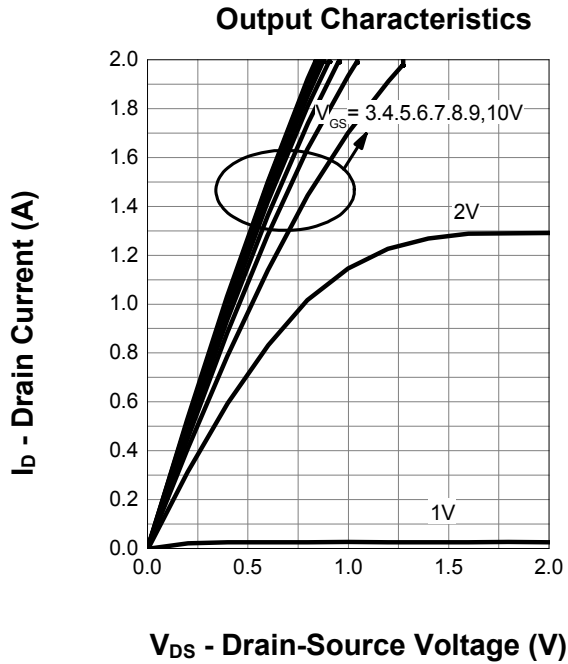

7. Typical Characteristics (cont.)

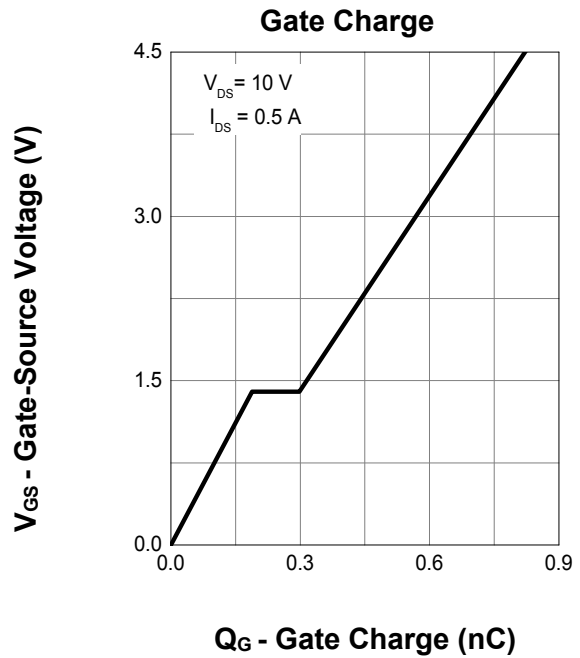
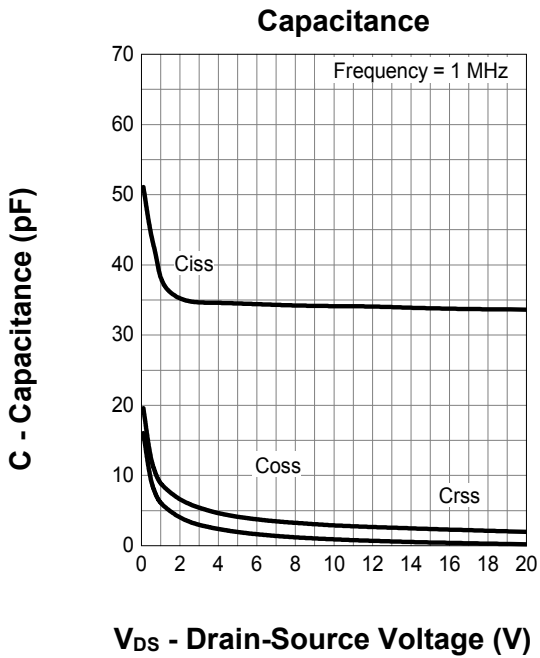
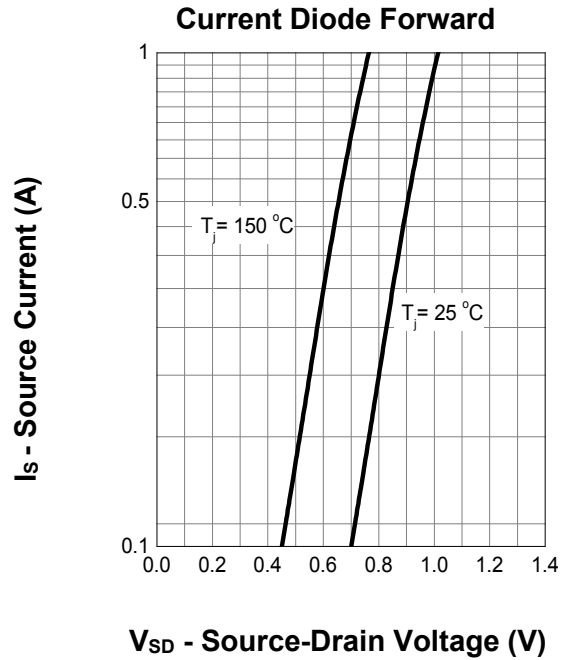
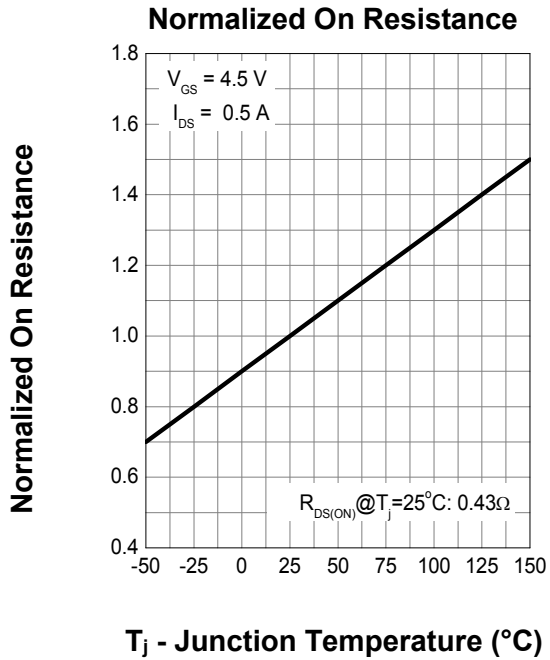

8. Package Dimensions

SOT523 Package

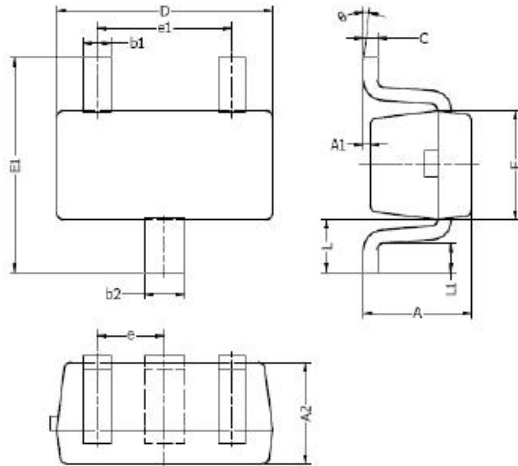

Typical Soldering Pattern:

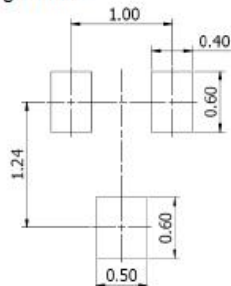

DIM	MILLIMETERS		INCHES	
	MIN	MAX	MIN	MAX
A	0.70	0.90	0.028	0.035
A1	0.00	0.10	0.000	0.004
A2	0.70	0.80	0.028	0.031
b1	0.15	0.25	0.006	0.010
b2	0.25	0.35	0.010	0.014
c	0.10	0.20	0.004	0.008
D	1.50	1.70	0.059	0.067
E	0.70	0.90	0.028	0.035
E1	1.45	1.75	0.057	0.069
e	0.50 TYP.		0.020 TYP.	
e1	0.90	1.10	0.035	0.043
L	0.40 REF.		0.016 REF.	
L1	0.10	0.30	0.004	0.012
θ	0°	8°	0°	8°

NOTES:

1. Above package outline conforms to JEITA EAIJ ED-7500A SC-75A.
2. Dimensions are exclusive of Burrs, Mold Flash & Tie Bar extrusions.